

SECM2913...T Serie 2-Phasen-Schrittmotor/Anschlußkasten [1,8° High-Torque-Version]

Model AE = Single Shaft T = Terminal Box	● Bipolar Parallel				● Bipolar Serial				● Unipolar				Torque Speed- curve
	Holding Torque [Nm]	Current/ Phase [A]	Resistance/ Phase [Ohm]	Inductance/ Phase [mH]	Holding Torque [Nm]	Current/ Phase [A]	Resistance/ Phase [Ohm]	Inductance/ Phase [mH]	Holding Torque [Nm]	Current/ Phase [A]	Resistance/ Phase [Ohm]	Inductance/ Phase [mH]	
SECM2913-E4.0AE-T	10.20	5.7	0.43	4.6	10.20	2.8	1.7	18.4	7.40	4.0	0.85	4.6	M1
SECM2913-E6.4AE-T	9.80	9.0	0.19*	1.7	9.80	4.5	0.76*	6.8	7.20	6.4	0.38*	1.7	M2

Number of Leads (Terminal Box)	Weight of Motor	Size Length	Rotor Inertia
8	5.4 kg	86 x 86 x 189.5 mm	4800 x 10 ⁻⁷ kgm ²

Resistance / Phase (Ω) = ± 15%, (* ± 20%), Inductance / Phase (mH) = ± 20%

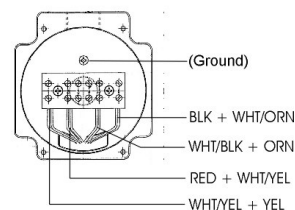
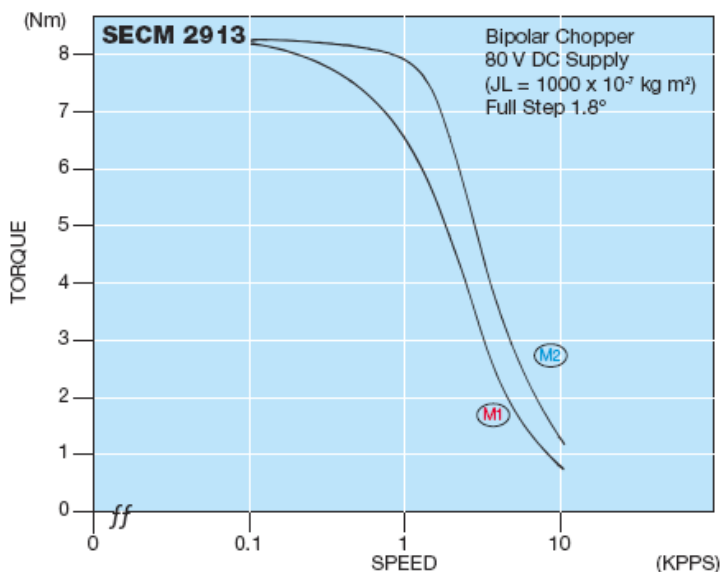
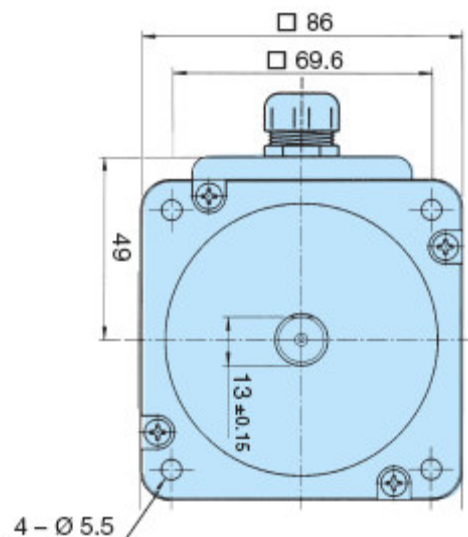
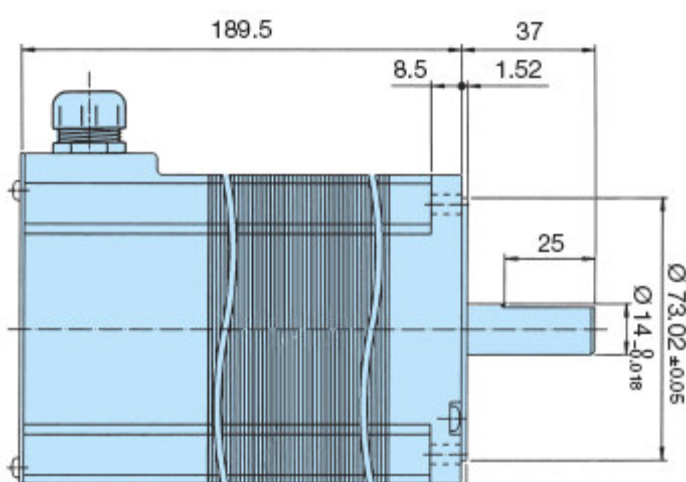

Planetengetriebe sind optional erhältlich