

# Schrittmotor mit Anschlußkasten:

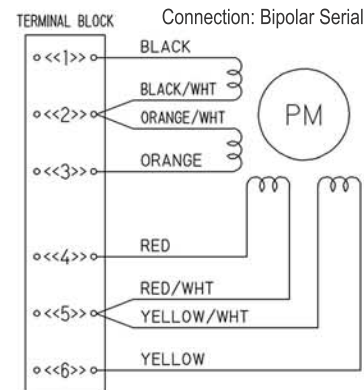

## 1.8° Vollschrittwinkel:

SECM264-E2.0A-T (Haltemoment = 0.50 Nm)	L = 69,5 mm
SECM264-E3.0A-T (Haltemoment = 0.50 Nm)	L = 69,5 mm
SECM266-E2.0A-T (Haltemoment = 1.17 Nm)	L = 84,5 mm
SECM266-E3.0A-T (Haltemoment = 1.17 Nm)	L = 84,5 mm
SECM268-E2.0A-T (Haltemoment = 1.75 Nm)	L = 106,5 mm
SECM268-E2.3A-T (Haltemoment = 1.75 Nm)	L = 106,5 mm
SECM268-E3.0A-T (Haltemoment = 1.75 Nm)	L = 106,5 mm

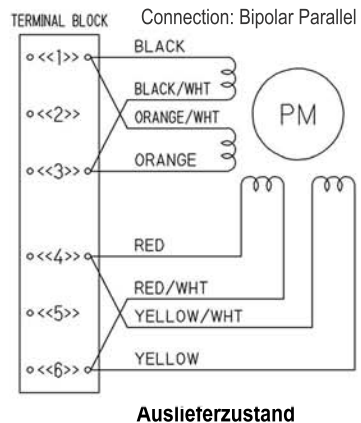
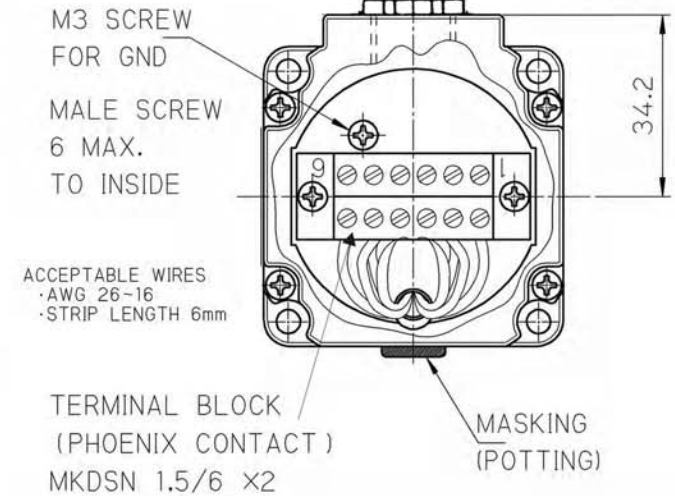
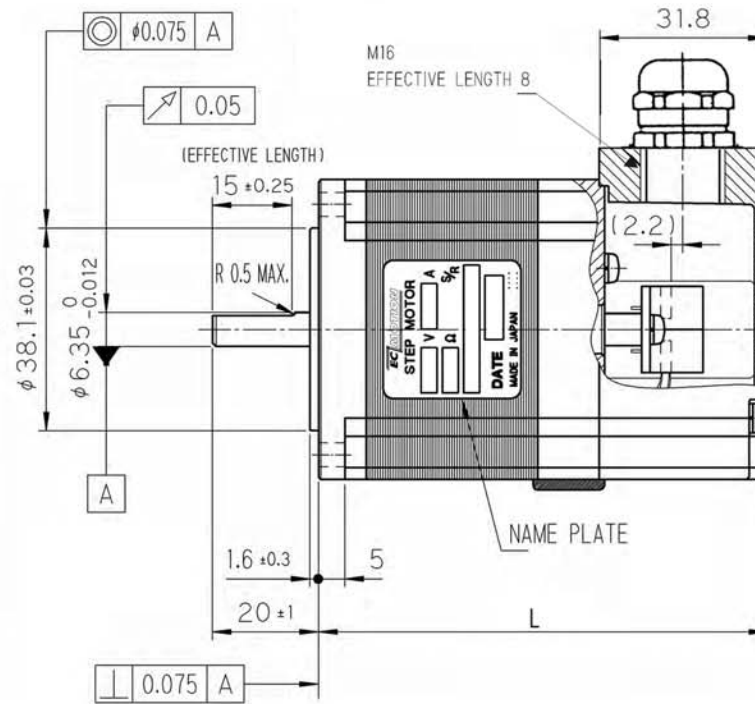
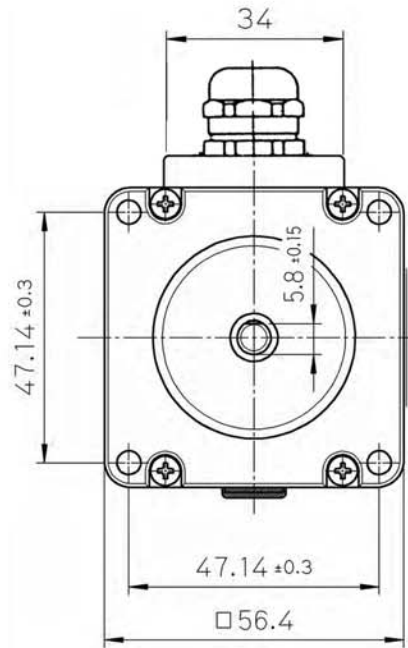
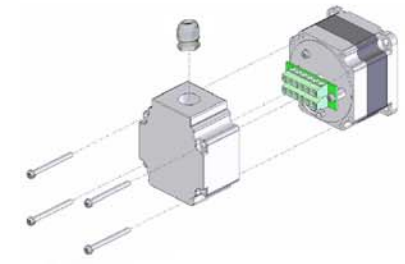

SECM264 / SECM266 / SECM268

Auf den Steinen 20 - 41812 Erkelenz  
Tel.: +49-2164-7014-0 - Fax: -701419  
www.ec-motion.de - info@ec-motion.de

**2-Phasen-Schrittmotor  
mit Anschlußkasten**

# EC MOTION



## SECM268... Serie 2-Phasen-Schrittmotor [1,8° High-Torque-Version]

Model A = Single Shaft B = Double Shaft	● Bipolar Parallel				● Bipolar Serial				● Unipolar				Torque Speed-curve
	Holding Torque [Nm]	Current/Phase [A]	Resistance/Phase [Ohm]	Inductance/Phase [mH]	Holding Torque [Nm]	Current/Phase [A]	Resistance/Phase [Ohm]	Inductance/Phase [mH]	Holding Torque [Nm]	Current/Phase [A]	Resistance/Phase [Ohm]	Inductance/Phase [mH]	
SECM268-E1.0 (A/B)	1.75	1.4	4.1	14.0	1.75	0.7	16.4	56.0	1.35	1.0	8.2	14.0	G1
SECM268-E2.0 (A/B)	1.75	2.8	1.2	3.6	1.75	1.4	4.6	14.4	1.35	2.0	2.3	3.6	G2
SECM268-E2.3 (A/B)	1.75	3.3	0.9	2.8	1.75	1.65	3.4	11.2	1.35	2.3	1.7	2.8	G3
SECM268-E3.0 (A/B)	1.75	4.2	0.5*	1.6	1.75	2.1	2.0*	6.4	1.35	3.0	1.0*	1.6	G4

Number of Leads	Weight of Motor	Size Length	Rotor Inertia
8	1.0 kg	56.4 x 56.4 x 76 mm	430 x 10 <sup>-7</sup> kgm <sup>2</sup>

Resistance / Phase (Ω) = ± 10%, (\* ± 15%), Inductance / Phase (mH) = ± 20%

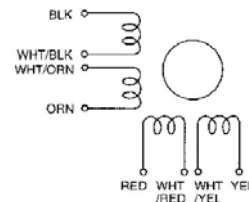
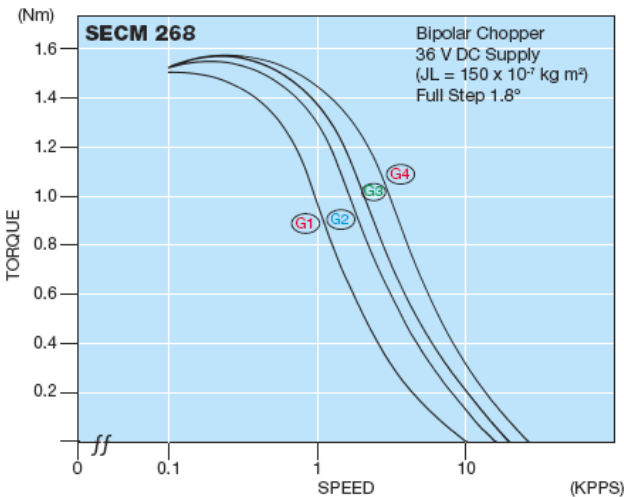
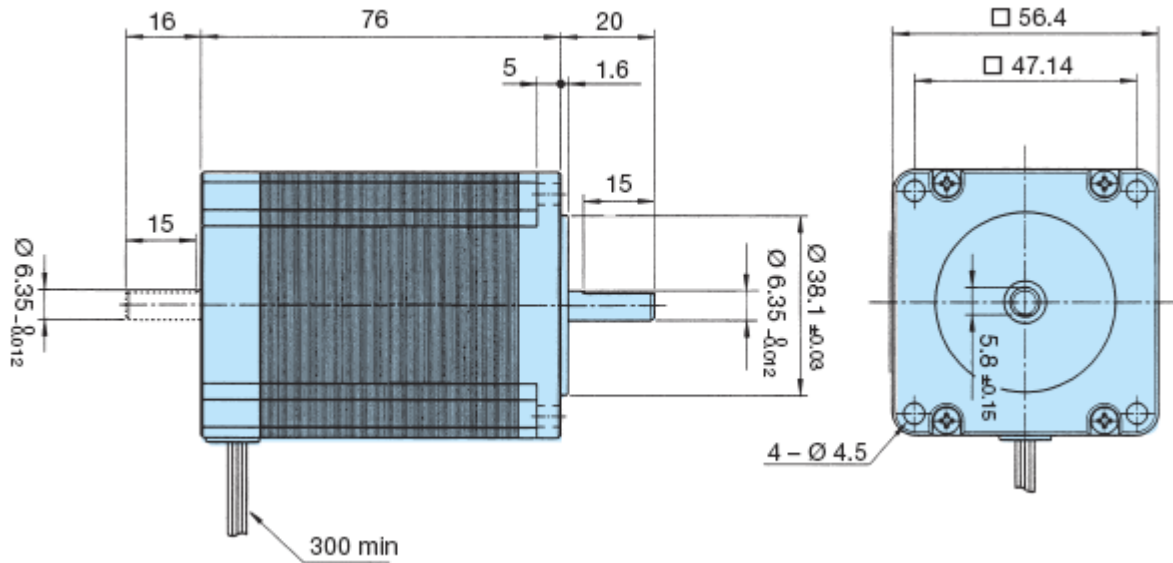

Planetengetriebe / Encoder sind optional erhältlich



EC Motion GmbH - Auf den Steinen 20 - 41812 Erkelenz  
Tel.: +49 (0)2164-7014-0 - Fax.: +49 (0)2164-701419  
Internet: www.ec-motion.de - e-mail: info@ec-motion.de

