



## SECM266 Baureihe

### 2-Phasen-Schrittmotor mit Encoder [1,8° High-Torque-Version]

Model	● Bipolar Parallel				● Bipolar Seriell				● Unipolar				Speed Torque
	Holding Torque [Nm]	Current / Phase [A]	Resistance / Phase [Ohm]	Inductance / Phase [mH]	Holding Torque [Nm]	Current / Phase [A]	Resistance / Phase [Ohm]	Inductance / Phase [mH]	Holding Torque [Nm]	Current / Phase [A]	Resistance / Phase [Ohm]	Inductance / Phase [mH]	
SECM266-E2.0P2200	1.17	2.8	0.9	2.5	1.17	1.4	3.6	10	0.9	1	7.2	11	○

Number of Leads	Weight of Motor & Encoder	Size Length	Rotor Inertia
8	0.78 kg	74.7 mm	260 x 10 <sup>-7</sup> kgm <sup>2</sup>

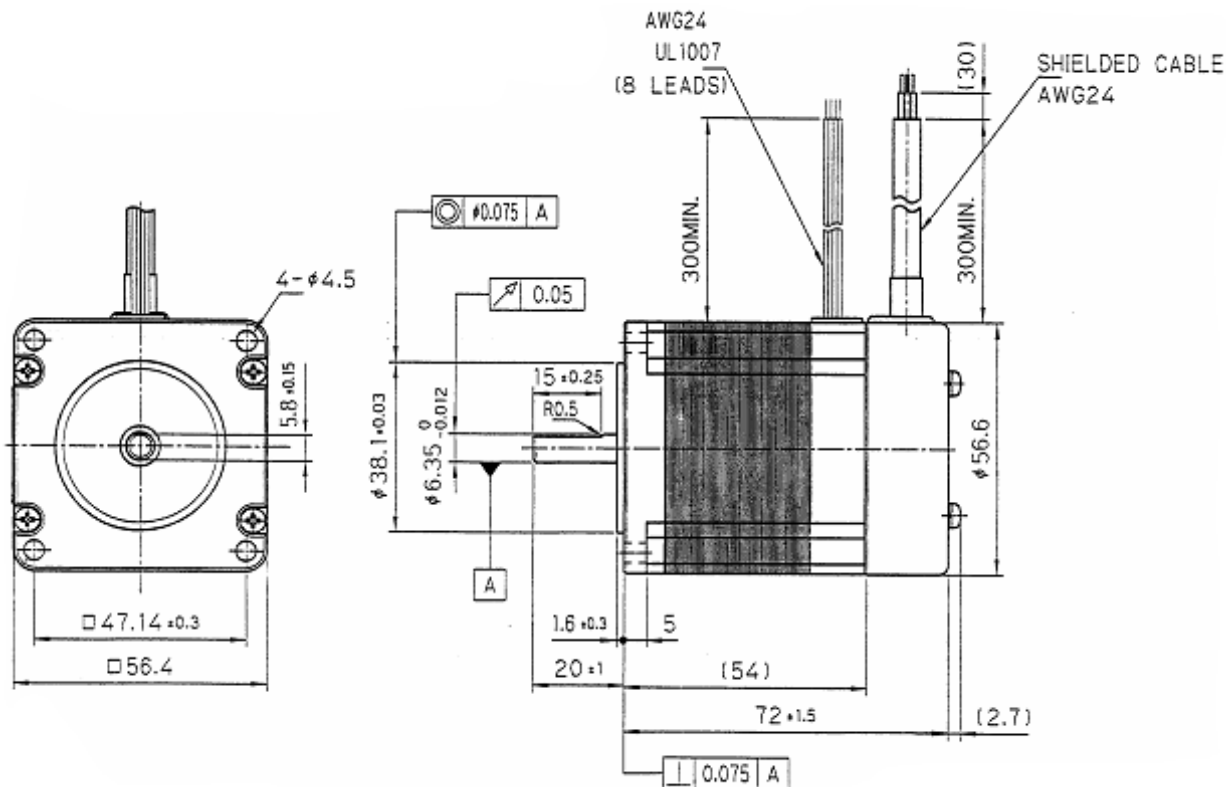

Optional sind für unsere Schrittmotoren Planetengetriebe erhältlich.

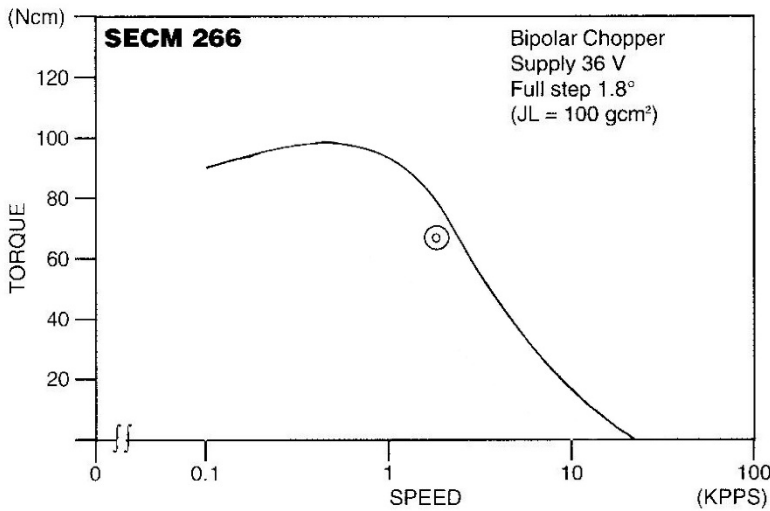

## Schrittmotoranschluss

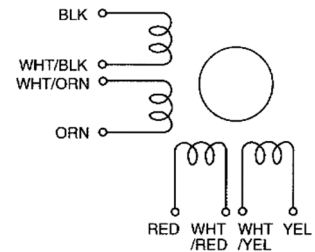

## Encoder Performance

Operating Temp.range : 0°C – 85°C  
 Supply : DC 5V ± 5% , 100mA max  
 Resolution : 200 Counts / Turn  
 Frequency Response : 100K Hz max.  
 A phase difference : 1/4 P ± 1/8 P  
 Code : Incremental A.B (2Ch.)

Output Signal : when output is high : DC 2.4V min  
 Output Signal : when output is low : DC 0.4V max  
 Sinking & Output Current : typical ± 20mA max  
 Rise & Fall Times : 1 µsec max  
 Moment of inertia : 5 g·cm<sup>2</sup> max Encoder only  
 Output Circuit : Line Driver AM26C3IIDB

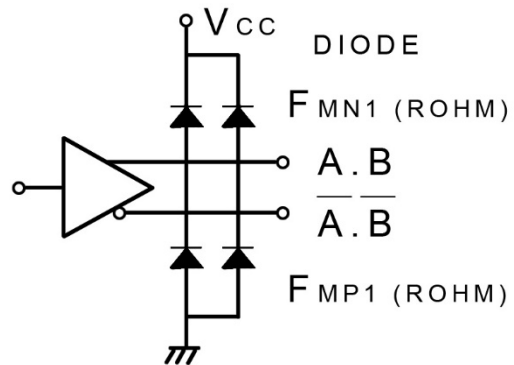
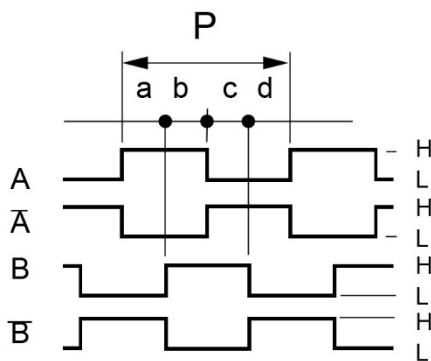

CW Rotation viewed from mounting end. Encoder signal A and B position is "H" at Motor 2Phase on.

## Color of Leadwires and Funktion :

DC 5V = red      A phase = brown      A-bar phase = orange  
 GND = blue      B phase = yellow      B-bar phase = gray

(Old-Version)

A phase = brown      A-bar phase = orange  
 B phase = yellow      B-bar phase = white  
 DC 5V = red      GND = black