

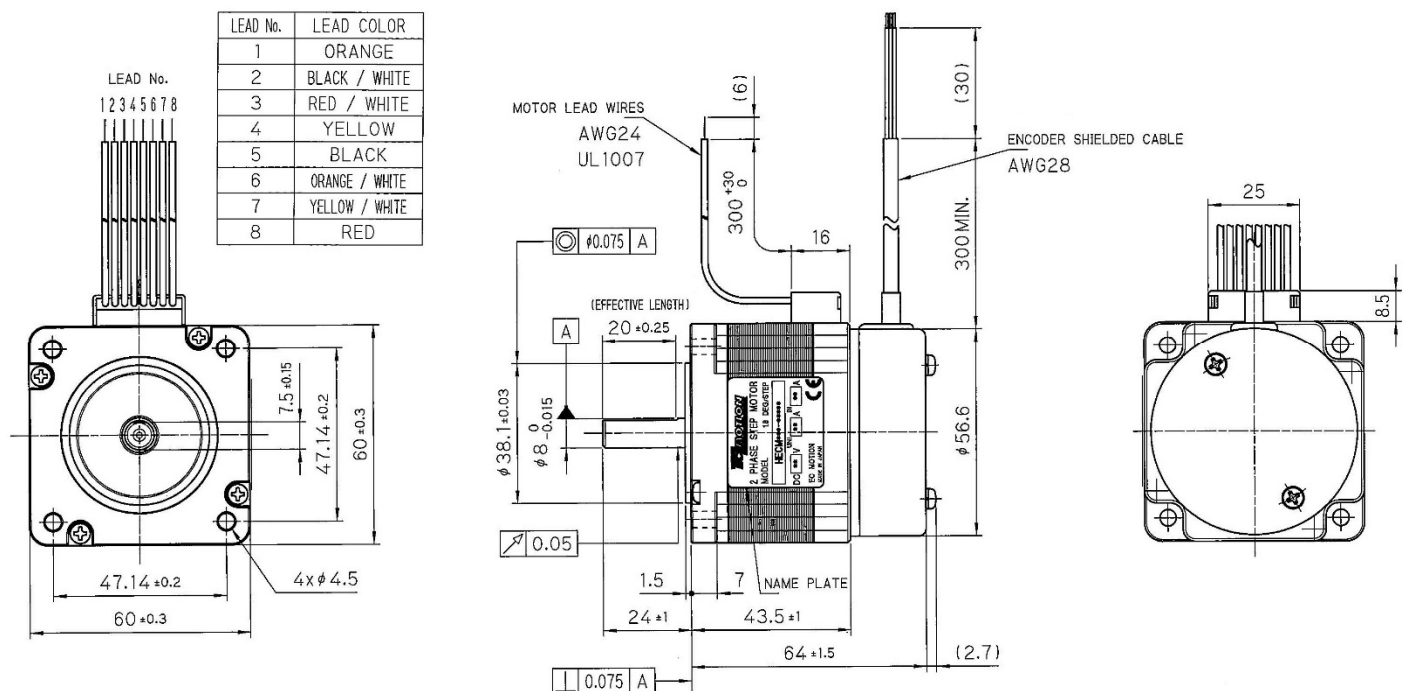

HECM264... Baureihe 2-Phasen-Schrittmotor mit Encoder [1,8° High-Torque-Version]

Model	● Bipolar Parallel				● Bipolar Seriell				● Unipolar				Speed Torque
	Holding Torque [Nm]	Current / Phase [A]	Resistance / Phase [Ohm]	Inductance / Phase [mH]	Holding Torque [Nm]	Current / Phase [A]	Resistance / Phase [Ohm]	Inductance / Phase [mH]	Holding Torque [Nm]	Current / Phase [A]	Resistance / Phase [Ohm]	Inductance / Phase [mH]	
HECM264-E2.0P2200	1.15	2.8	0.73	2.1	1.15	1.4	2.9	8.4	0.85	2.0	1.45	2.1	A1

Number of Leads	Weight of Motor & Encoder	Size Length	Rotor Inertia
8	0.7 kg	66.7 mm	280 x 10 ⁻⁷ kgm ²



Optional sind für unsere Schrittmotoren Planetengetriebe erhältlich.

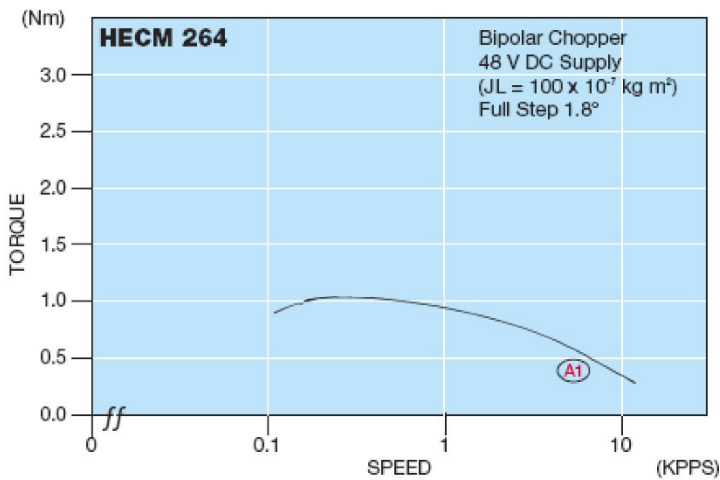

Schrittmotoranschluss

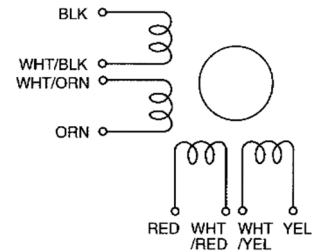

Encoder Performance

Operating Temp.range : 0°C – 85°C
 Supply : DC 5V ± 5% , 100mA max
 Resolution : 200 Counts / Turn
 Frequency Response : 100K Hz max.
 A phase difference : 1/4 P ± 1/8 P
 Code : Incremental A.B (2Ch.)

Output Signal : when output is high : DC 2.4V min
 Output Signal : when output is low : DC 0.4V max
 Sinking & Output Current : typical ± 20mA max
 Rise & Fall Times : 1 µsec max
 Moment of inertia : 5 g·cm² max Encoder only
 Output Circuit : Line Driver AM26C3IIDB

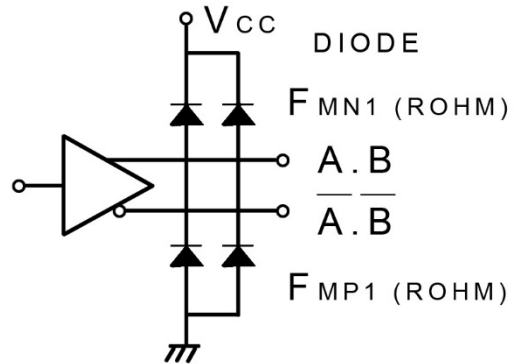
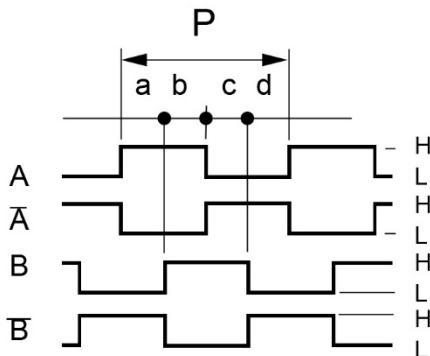

CW Rotation viewed from P mounting end. Encoder signal A and B position is "H" at Motor 2Phase on.

Color of Leadwires and Funktion :

DC 5V = red A phase = brown A-bar phase = orange
 GND = blue B phase = yellow B-bar phase = gray

(Old-Version)

A phase = brown A-bar phase = orange
 B phase = yellow B-bar phase = white
 DC 5V = red GND = black