



HECM246... Baureihe

2-Phasen-Schrittmotor mit Encoder
[1,8° High-Torque-Version]

Model	● Bipolar (4 Leads)				● Unipolar				Speed Torque
	Holding Torque [Nm]	Current / Phase [A]	Resistance / Phase [Ohm]	Inductance / Phase [mH]	Holding Torque [Nm]	Current / Phase [A]	Resistance / Phase [Ohm]	Inductance / Phase [mH]	
P = Line Driver 200 Pulse/Umd. HECM246-F1.3P2200	0.93	1.3	5.2	10.0	—	—	—	—	I1

Number of Leads	Weight of Motor & Encoder	Size Length	Rotor Inertia
4	0.50 kg	81 mm	$114 \times 10^{-7} \text{ kgm}^2$

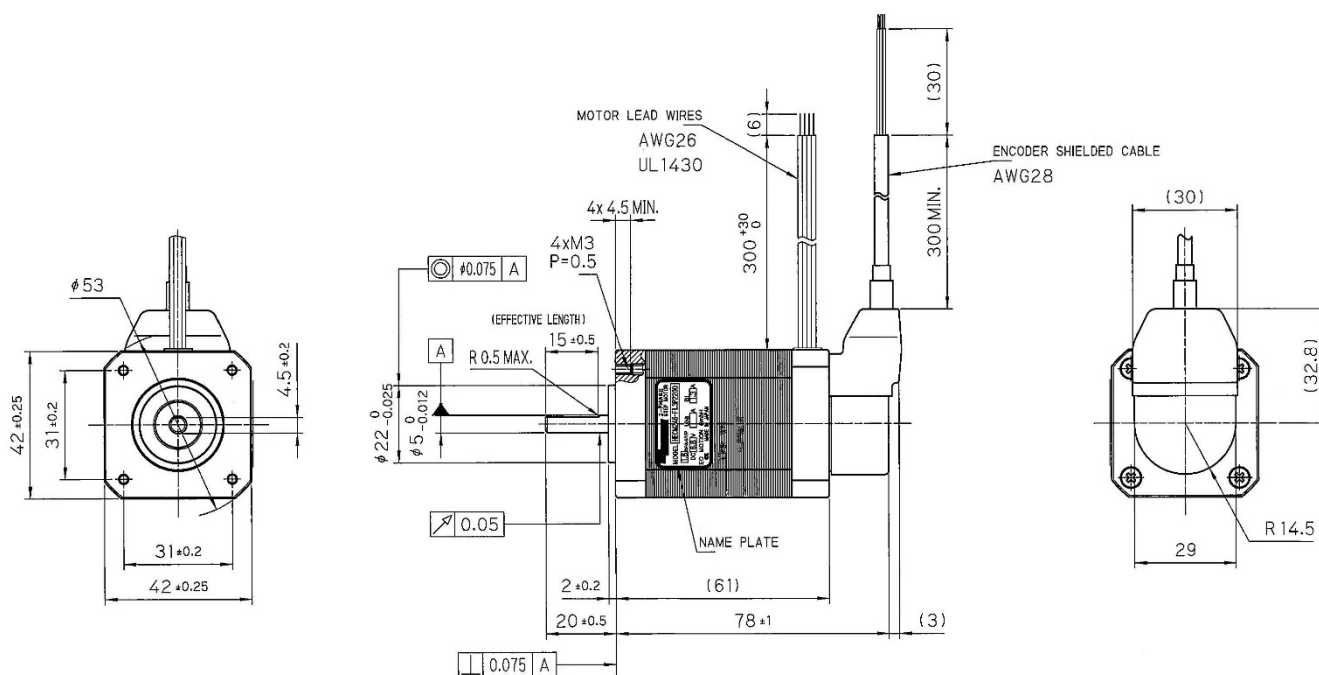

Optional sind für unsere Schrittmotoren auch Planetengetriebe erhältlich.



EC Motion GmbH - Auf den Steinen 20 - 41812 Erkelenz
Tel.: +49 (0)2164-7014-0 - Fax. : +49 (0)2164-701419
Internet: www.ec-motion.de - e-mail: info@ec-motion.de



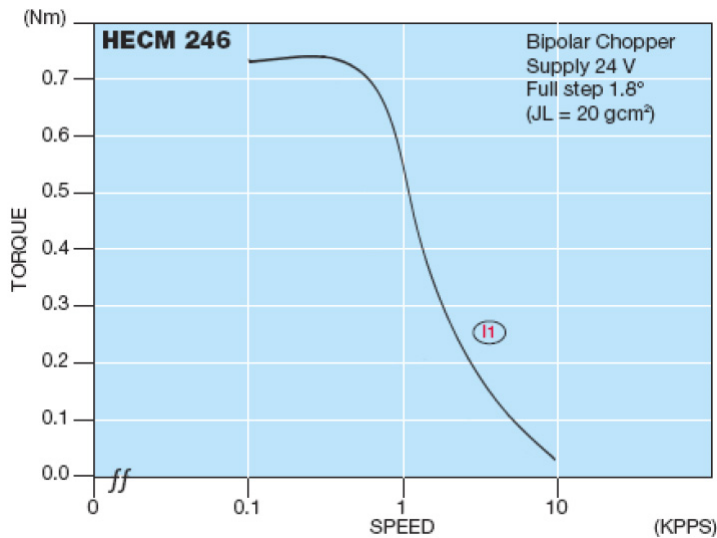

Schrittmotoranschluss

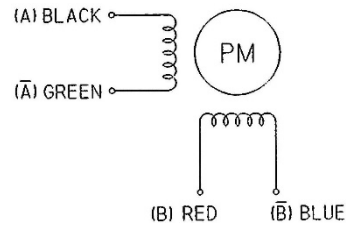

Encoder Performance

Operating Temp.range : 0°C – 85°C
 Supply : DC 5V ± 5% , 100mA max
 Resolution : 200 Counts / Turn
 Frequency Response : 100K Hz max.
 A phase difference : 1/4 P ± 1/8 P
 Code : Incremental A.B (2Ch.)

Output Signal : when output is high : DC 2.4V min
 Output Signal : when output is low : DC 0.4V max
 Sinking & Output Current : typical ± 20mA max
 Rise & Fall Times : 1 µsec max
 Moment of inertia : 5 g-cm² max Encoder only
 Output Circuit : Line Driver AM26C31IDB

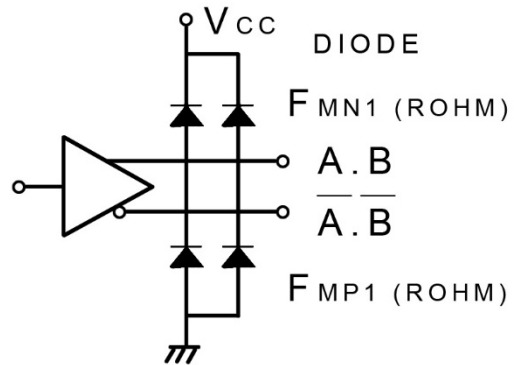
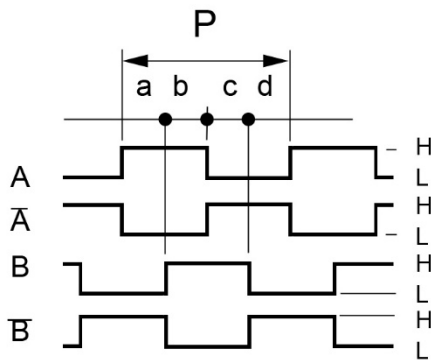

CW Rotation viewed from mounting end. Encoder signal A and B position is "H" at Motor 2Phase on.

Color of Leadwires and Funktion :

DC 5V = red A phase = brown A-bar phase = orange
 GND = blue B phase = yellow B-bar phase = gray

(Old-Version)

A phase = brown A-bar phase = orange
 B phase = yellow B-bar phase = white
 DC 5V = red GND = black