

ECM243M... Serie 2-Phasen-Schrittmotor [0,9° Standard-Torque-Version]

Model A = Single Shaft B = Double Shaft	● Bipolar Seriell				● Unipolar				Speed Torque
	Holding Torque [Nm]	Current / Phase [A]	Resistance / Phase [Ohm]	Inductance / Phase [mH]	Holding Torque [Nm]	Current / Phase [A]	Resistance / Phase [Ohm]	Inductance / Phase [mH]	
ECM243M-S0.9 (A/B)	0.10	0.64	8.8	10.0	0.08	0.90	4.4	2.5	J1
ECM243M-S0.3 (A/B)	0.10	0.21	80.0	84.0	0.08	0.30	40.0	21.0	J2

Number of Leads	Weight of Motor	Size Length	Rotor Inertia
6	0.2 kg	33 mm	19 x 10 ⁻⁷ kgm ²

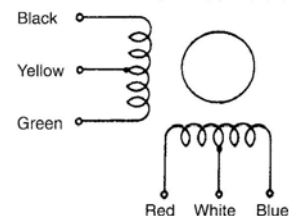
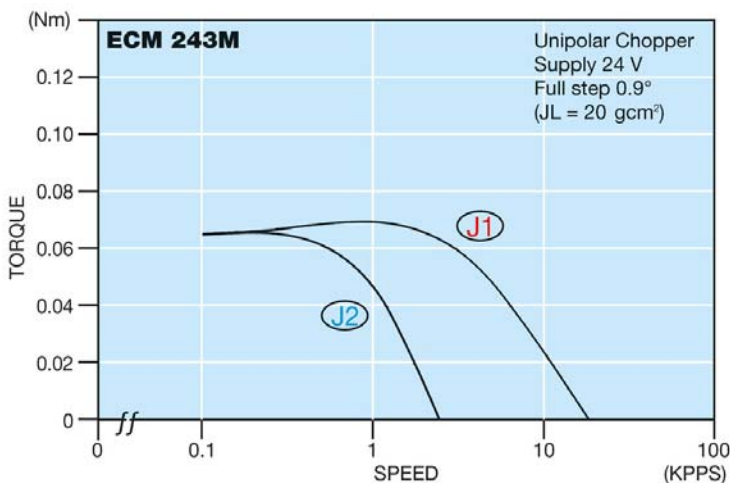
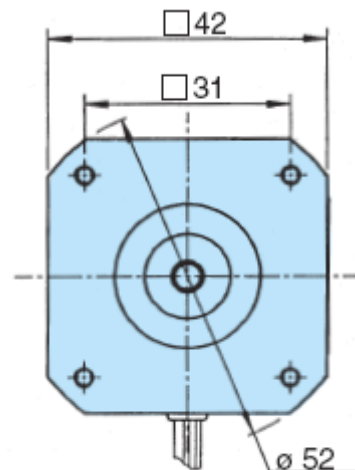
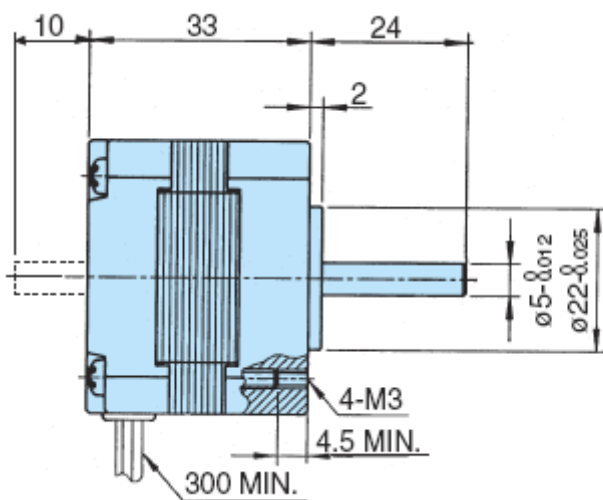

Planetengetriebe sind optional erhältlich