

Brake BRK26S - Technical Data

Voltage: 24 VDC
 Watt: 9.5 W
 Holdingtorque: 3.3 Nm
 Coil Resistance: 47.3 up to 55.8 Ohm
 Duty Cycle: 50%
 Weight: 0.45 kg

Step Motor - Technical Data

Length (L):

SECM264...B = 39 mm
 SECM266...B = 54 mm
 SECM268...B = 76 mm

SECM264M...B = 39 mm
 SECM266M...B = 54 mm
 SECM268M...B = 76 mm

Holding Torque:

SECM264...B = 0.50 Nm
 SECM266...B = 1.17 Nm
 SECM268...B = 1.75 Nm

SECM264M...B = 0.55 Nm
 SECM266M...B = 1.25 Nm
 SECM268M...B = 1.95 Nm

further data see Step Motor data sheet

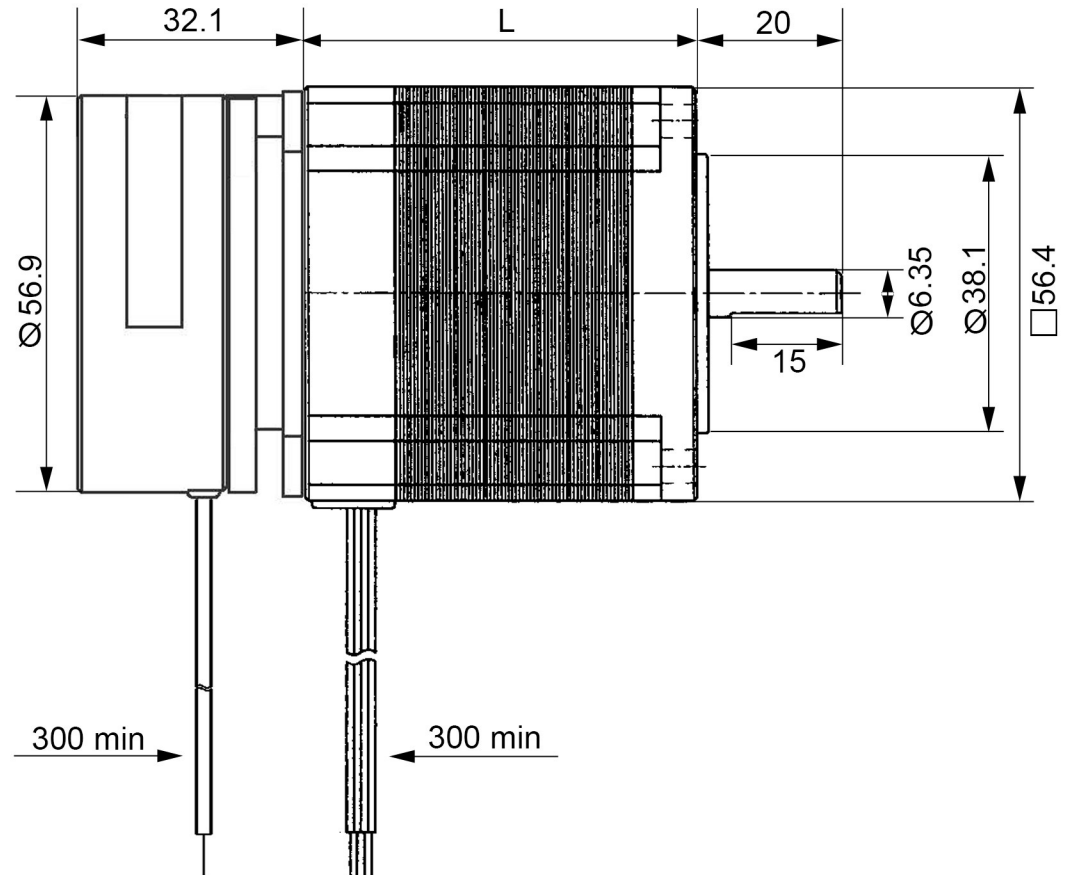

ECMOTION

SECM26-Series

Glockensprung (neu) 8
 41812 Erkelenz
 Tel.: +49-2431-94206-0
 www.ec-motion.de - info@ec-motion.de

**Step Motor with
 electromagnetic Brake**

Version 06/21

STEPPING MOTORS

□ 56.4 mm SECM-SPECIFICATIONS

1.8° HIGH-TORQUE 2 PHASE STEPPING MOTOR

Model A = Single Shaft B = Double Shaft	● Bipolar Parallel				● Bipolar Serial				● Unipolar				Torque Speed-curve
	Holding Torque [Nm]	Current/Phase [A]	Resistance/Phase [Ohm]	Inductance/Phase [mH]	Holding Torque [Nm]	Current/Phase [A]	Resistance/Phase [Ohm]	Inductance/Phase [mH]	Holding Torque [Nm]	Current/Phase [A]	Resistance/Phase [Ohm]	Inductance/Phase [mH]	
SECM264-E1.0 (A/B)	0.50	1.4	2.6	5.4	0.50	0.7	10.4	21.6	0.39	1.0	5.2	5.4	E1
SECM264-E2.0 (A/B)	0.50	2.8	0.7	1.4	0.50	1.4	2.8	5.6	0.39	2.0	1.4	1.4	E2
SECM264-E3.0 (A/B)	0.50	4.2	0.3*	0.5	0.50	2.1	1.2*	2.0	0.39	3.0	0.6*	0.5	E2

Number of Leads	Weight of Motor	Size Length	Rotor Inertia
8	0.45 kg	56.4 x 56.4 x 39 mm	120 x 10 ⁻⁷ kgm ²

Resistance / Phase (Ω) = ± 10%, (* ± 15%), Inductance / Phase (mH) = ± 20%

Model A = Single Shaft B = Double Shaft	● Bipolar Parallel				● Bipolar Serial				● Unipolar				Torque Speed-curve
	Holding Torque [Nm]	Current/Phase [A]	Resistance/Phase [Ohm]	Inductance/Phase [mH]	Holding Torque [Nm]	Current/Phase [A]	Resistance/Phase [Ohm]	Inductance/Phase [mH]	Holding Torque [Nm]	Current/Phase [A]	Resistance/Phase [Ohm]	Inductance/Phase [mH]	
SECM266-E1.0 (A/B)	1.17	1.4	3.6	11.0	1.17	0.7	14.4	44.0	0.90	1.0	7.2	11.0	F1
SECM266-E2.0 (A/B)	1.17	2.8	0.9	2.5	1.17	1.4	3.6	10.0	0.90	2.0	1.8	2.5	F2
SECM266-E3.0 (A/B)	1.17	4.2	0.4*	1.2	1.17	2.1	1.6*	4.8	0.90	3.0	0.8*	1.2	F3

Number of Leads	Weight of Motor	Size Length	Rotor Inertia
8	0.7 kg	56.4 x 56.4 x 54 mm	260 x 10 ⁻⁷ kgm ²

Resistance / Phase (Ω) = ± 10%, (* ± 15%), Inductance / Phase (mH) = ± 20%

Model A = Single Shaft B = Double Shaft	● Bipolar Parallel				● Bipolar Serial				● Unipolar				Torque Speed-curve
	Holding Torque [Nm]	Current/Phase [A]	Resistance/Phase [Ohm]	Inductance/Phase [mH]	Holding Torque [Nm]	Current/Phase [A]	Resistance/Phase [Ohm]	Inductance/Phase [mH]	Holding Torque [Nm]	Current/Phase [A]	Resistance/Phase [Ohm]	Inductance/Phase [mH]	
SECM268-E1.0 (A/B)	1.75	1.4	4.1	14.0	1.75	0.7	16.4	56.0	1.35	1.0	8.2	14.0	G1
SECM268-E2.0 (A/B)	1.75	2.8	1.2	3.6	1.75	1.4	4.6	14.4	1.35	2.0	2.3	3.6	G2
SECM268-E2.3 (A/B)	1.75	3.3	0.9	2.8	1.75	1.65	3.4	11.2	1.35	2.3	1.7	2.8	G3
SECM268-E3.0 (A/B)	1.75	4.2	0.5*	1.6	1.75	2.1	2.0*	6.4	1.35	3.0	1.0*	1.6	G4

Number of Leads	Weight of Motor	Size Length	Rotor Inertia
8	1.0 kg	56.4 x 56.4 x 76 mm	430 x 10 ⁻⁷ kgm ²

Resistance / Phase (Ω) = ± 10%, (* ± 15%), Inductance / Phase (mH) = ± 20%

HECM / SECM - Series

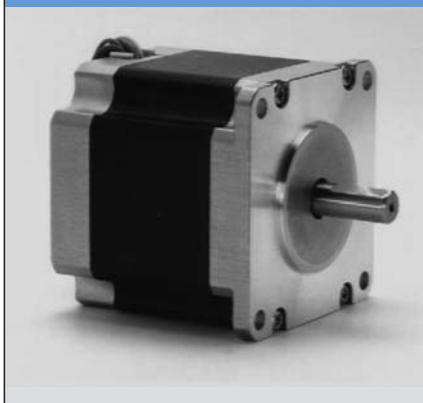

GENERAL SPECIFICATIONS

Items	Specifications
Shaft Runout	0.05 mm Max. T.I.R.
Shaft Radial Play	0.025 mm Max. (0.5 kg)
Shaft Axial Play	0.075 mm Max. (1 kg)
Insulation Resistance	100 M Ω (DC 500 V)
Dielectric Strength	500 V AC (1 Minute)
Insulation Class	CLASS B (130°)
Temperature Rise	80° C MAX. (2 PHASE ON)
Working Temperature	-20° C ~ + 50° C

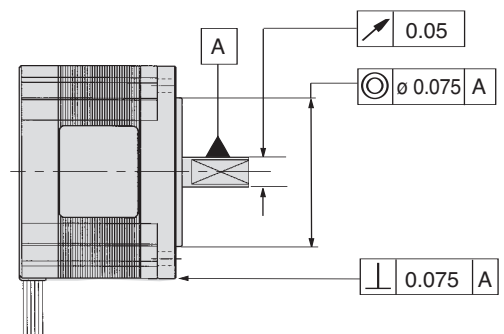

TORQUE VS. SPEED CHARACTERISTIC

Nm/KPPS (1000 PULSE/SECOND)

DIMENSIONS

UNIT = mm

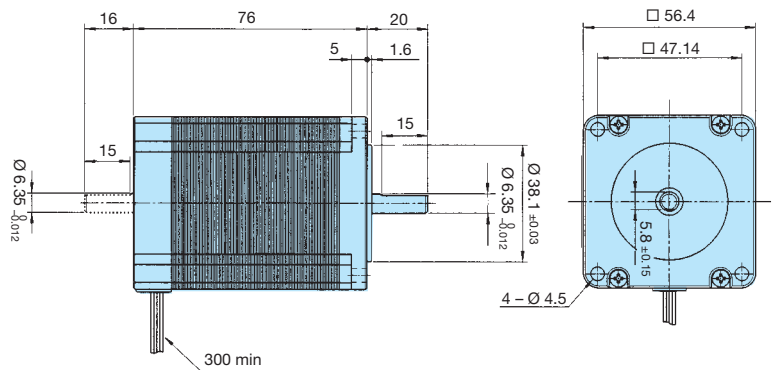
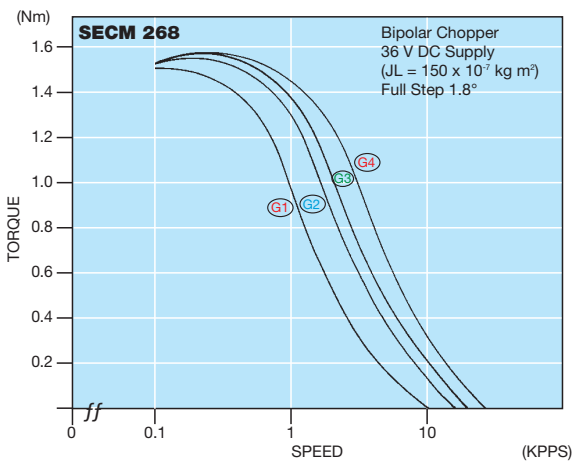
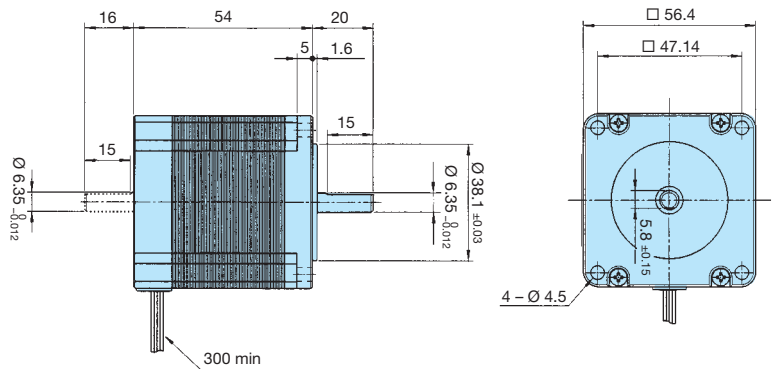
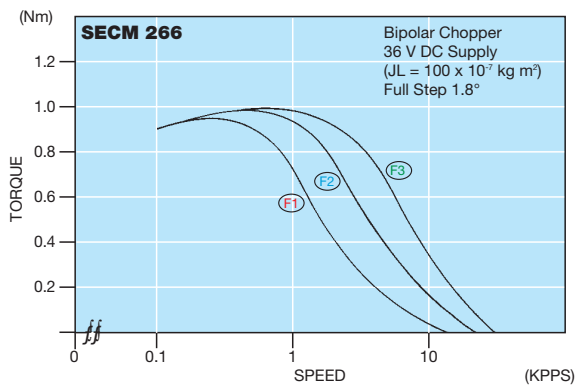
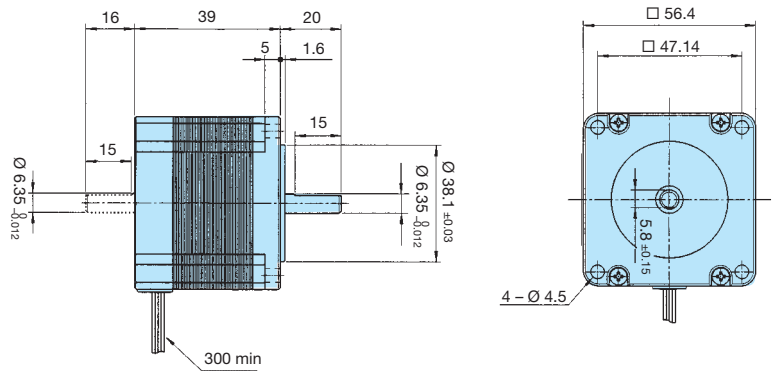
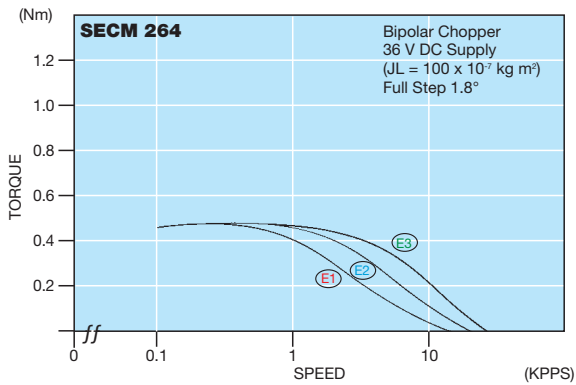

COLOR OF LEAD WIRES

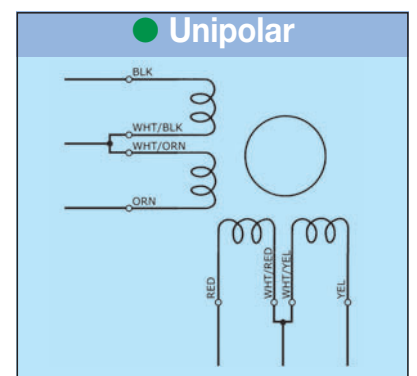
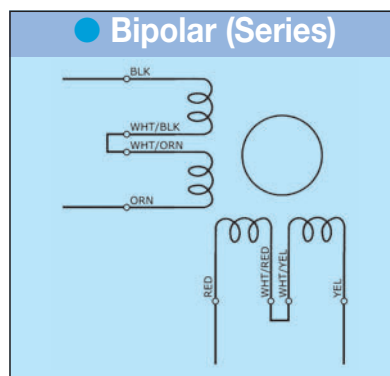
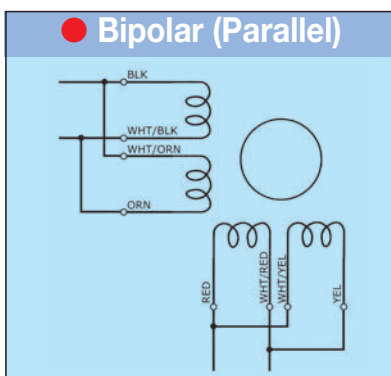

STEPPING MOTORS

□ 56.4 mm SECM-SPECIFICATIONS

0.9° HIGH-TORQUE 2 PHASE STEPPING MOTOR

Model A = Single Shaft B = Double Shaft	● Bipolar Parallel				● Bipolar Serial				● Unipolar				Torque Speed-curve
	Holding Torque [Nm]	Current/Phase [A]	Resistance/Phase [Ohm]	Inductance/Phase [mH]	Holding Torque [Nm]	Current/Phase [A]	Resistance/Phase [Ohm]	Inductance/Phase [mH]	Holding Torque [Nm]	Current/Phase [A]	Resistance/Phase [Ohm]	Inductance/Phase [mH]	
SECM264M-E1.0 (A/B)	0.55	1.4	2.8	8.4	0.55	0.7	11.2	33.6	0.44	1.0	5.6	8.4	(N1)
SECM264M-E2.0 (A/B)	0.55	2.8	0.7	2.2	0.55	1.4	2.8	8.8	0.44	2.0	1.4	2.2	(N2)
SECM264M-E3.0 (A/B)	0.55	4.2	0.3*	0.9	0.55	2.1	1.2*	3.6	0.44	3.0	0.6*	0.9	(N3)

Number of Leads	Weight of Motor	Size Length	Rotor Inertia
8	0.45 kg	56.4 x 56.4 x 39 mm	145 x 10 ⁻⁷ kgm ²

Resistance / Phase (Ω) = ± 10%, (* ± 15%), Inductance / Phase (mH) = ± 20%

Model A = Single Shaft B = Double Shaft	● Bipolar Parallel				● Bipolar Serial				● Unipolar				Torque Speed-curve
	Holding Torque [Nm]	Current/Phase [A]	Resistance/Phase [Ohm]	Inductance/Phase [mH]	Holding Torque [Nm]	Current/Phase [A]	Resistance/Phase [Ohm]	Inductance/Phase [mH]	Holding Torque [Nm]	Current/Phase [A]	Resistance/Phase [Ohm]	Inductance/Phase [mH]	
SECM266M-E1.0 (A/B)	1.25	1.4	3.6	23.1	1.25	0.7	14.4	92.4	0.95	1.0	7.2	23.1	(O1)
SECM266M-E2.0 (A/B)	1.25	2.8	0.9	5.9	1.25	1.4	3.6	23.6	0.95	2.0	1.8	5.9	(O2)
SECM266M-E3.0 (A/B)	1.25	4.2	0.4*	2.6	1.25	2.1	1.6*	10.4	0.95	3.0	0.8*	2.6	(O3)

Number of Leads	Weight of Motor	Size Length	Rotor Inertia
8	0.7 kg	56.4 x 56.4 x 54 mm	310 x 10 ⁻⁷ kgm ²

Resistance / Phase (Ω) = ± 10%, (* ± 15%), Inductance / Phase (mH) = ± 20%

Model A = Single Shaft B = Double Shaft	● Bipolar Parallel				● Bipolar Serial				● Unipolar				Torque Speed-curve
	Holding Torque [Nm]	Current/Phase [A]	Resistance/Phase [Ohm]	Inductance/Phase [mH]	Holding Torque [Nm]	Current/Phase [A]	Resistance/Phase [Ohm]	Inductance/Phase [mH]	Holding Torque [Nm]	Current/Phase [A]	Resistance/Phase [Ohm]	Inductance/Phase [mH]	
SECM268M-E2.0 (A/B)	1.95	2.8	1.15	7.8	1.95	1.4	4.6	31.2	1.45	2.0	2.3	7.8	(P1)
SECM268M-E2.4 (A/B)	1.95	3.5	0.75	5.0	1.95	1.75	3.0	20.0	1.45	2.45	1.5	5.0	(P2)
SECM268M-E3.0 (A/B)	1.95	4.2	0.5*	3.5	1.95	2.1	2.0*	14.0	1.45	3.0	1.0*	3.5	(P3)

Number of Leads	Weight of Motor	Size Length	Rotor Inertia
8	1.0 kg	56.4 x 56.4 x 76 mm	520 x 10 ⁻⁷ kgm ²

Resistance / Phase (Ω) = ± 10%, (* ± 15%), Inductance / Phase (mH) = ± 20%

SECM 26... Series 0.9°

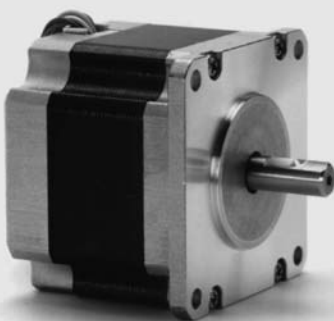

GENERAL SPECIFICATIONS

Items	Specifications
Shaft Runout	0.05 mm Max. T.I.R.
Shaft Radial Play	0.025 mm Max. (0.5 kg)
Shaft Axial Play	0.075 mm Max. (1 kg)
Insulation Resistance	100 M Ω (DC 500 V)
Dielectric Strength	500 V AC (1 Minute)
Insulation Class	CLASS B (130°)
Temperature Rise	80° C MAX. (2 PHASE ON)
Working Temperature	-20° C ~ + 50° C

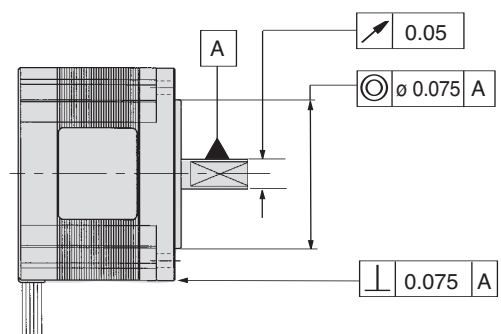

TORQUE VS. SPEED CHARACTERISTIC

Nm/KPPS (1000 PULSE/SECOND)

DIMENSIONS

UNIT = mm

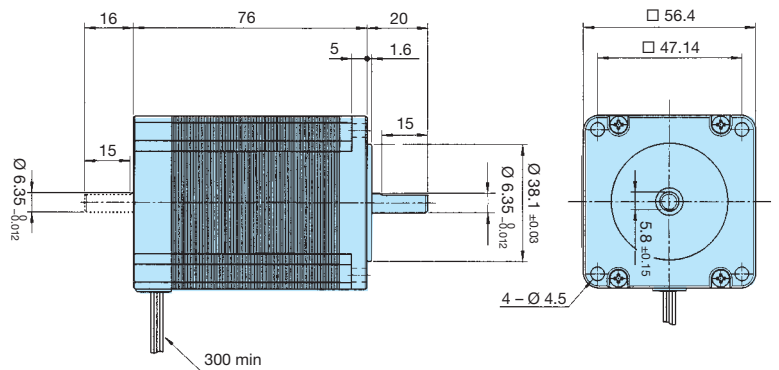
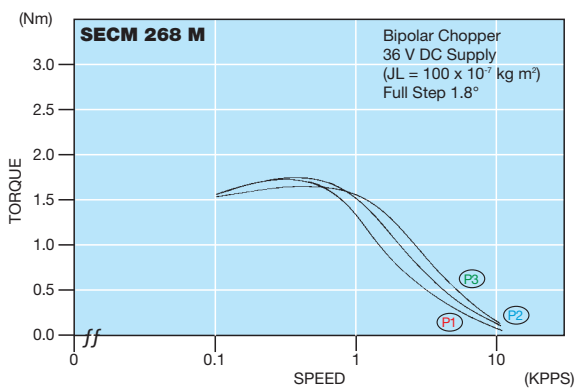
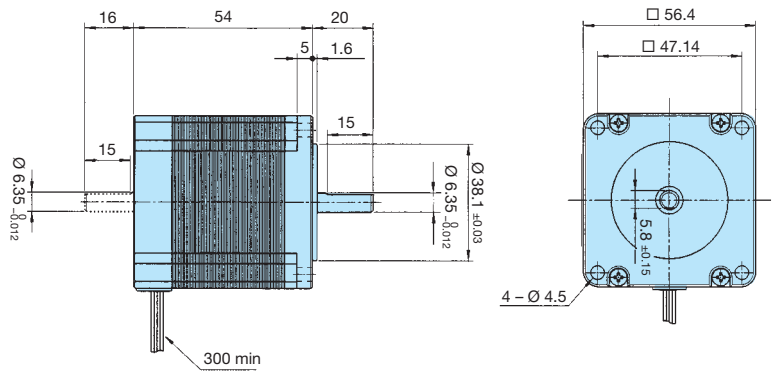
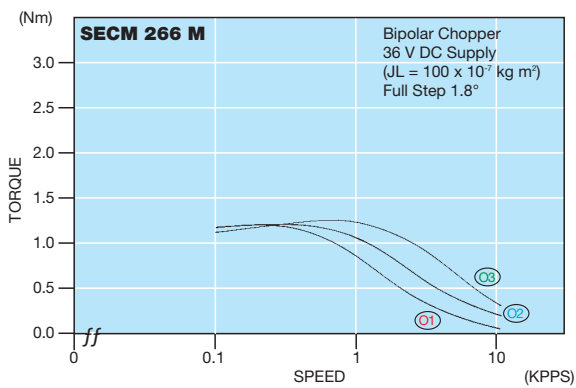
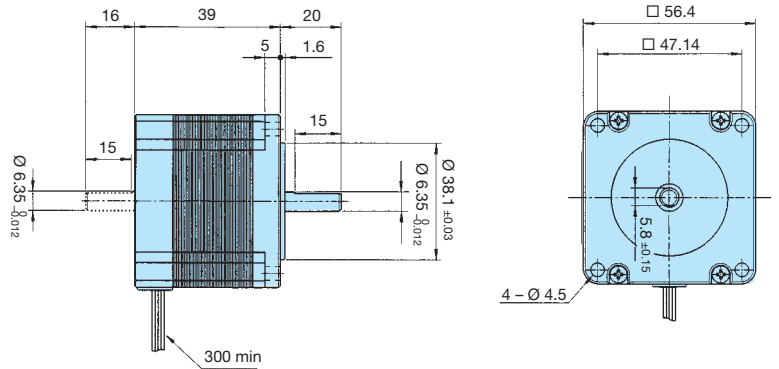
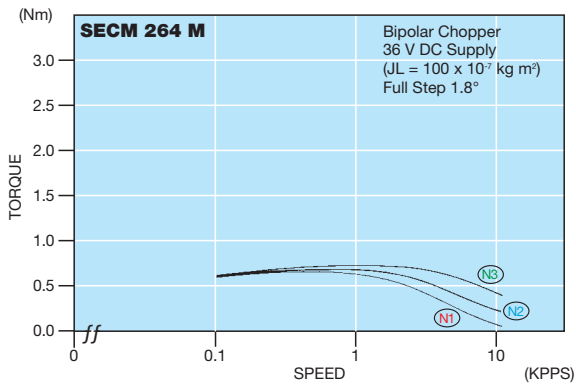

COLOR OF LEAD WIRES

