



Manual

„Blue Power Line “

ECMD288

2-Phase-Stepp Motor Driver



Revision: 09/2010 subject to change without prior notice

Product Features

- for HECM264...269, SECM264...2913 - Series
- only one supply voltage from 24 to 80 Volt required
- Motor phase current from 1.5 to 8.0 Amps
We recommend to attach our Heat-Sink and/or suitable Cooling-Fan from approx. 50% of the max. Phase-Current of driver
- A variety of selectable step resolutions per revolution
200, 400, 500, 1000, 2000, 2500, 5000 und 10000
- Automatic motor set up at power on
- High dynamic in the upper speed range
- High torque during acceleration
- Quiet at stand still due to StandBy Mode
- High and constant torque from step to step
- Drive: bipolar, very low noise and losses
- Inputs: (opto isolator)
PULSE, DIRECTION, IN1[OFF, RESET, GATE]
Wide range input 3,5...24V, Step frequency up to 250 kHz
- Outputs: (opto isolator) READY
- Protected against over-current, over-temperature, over-voltage and low voltage
- Extensive device status information with LEDs
- Automatic current reduction at stand still
- Variable boost-function at acceleration
- Active ballast circuit protects from over-voltage

Ordering Number Key

ECMD288.000	
Stepper Motor Drive	_____
Series Motor Type	-----
2	2 Phase Step Motor
Series Nominal Voltage	_____
8	24...80Vdc
Series Nominal Current	-----
8	1,5...6,0Amps
Cooling	_____
0	without Heat Sink
1	with Heat Sink
Housing Version	-----
0	with Housing
1	without Housing
Mounting	_____
0	Wall mount
1	with DIN rail mounting clip

Stepper Motor Technology new defined

This power drive sets new standards for the digital control of stepping motors. Utilizing a state-of-the-art digital signal processor (DSP) made it possible to develop new procedures and control technologies. The result is a low cost and very compact power drive especially efficient in highly dynamic applications. The robust drive is suitable for rough industrial environments. A wide range of 2-phase and 3-phase stepping motors (sizes NEMA23,24 and 34) can be covered.

Automatic Controller Setup

At power on, the drive electronically analyzes the motor. Next the operating parameters are automatically tuned to achieve optimal dynamic and smooth run drive performance. Consequently the power drive adjusts itself to the respective motor. Specific power drive know how is therefore not required.

Boost and Current Reduction

A variable boost function is enabled depending on the actual acceleration rate, i.e. an additional current offset is added to the set current value. With this, higher acceleration rates are possible. The current reduction reduces the motor current at stand still to 60% of the set current value.

Dynamic Operating Parameter Adjustment

Several conditions are continuously monitored during operation and the operating parameters are automatically adjusted. As a result the constant motor torque range stretches and dynamic positioning moves are also possible in the higher speed range.

StandBy Mode

With lower speeds down to stand still the power drive gradually switches to the stand by mode. The motor is absolutely quiet and this with full torque. A big advantage for office and lab environments.

Digital Phase Current Controller

The power drive design is fully digital and the phase current is measured directly in the motor windings. The strict focus was here to achieve optimal operating performance such as low resonance run, high step angle accuracy and high and constant torque from step to step.

Options:

- Open frame,
- Wallmount or with DIN-rail mounting clip
- Heat sink

Set-up Elements

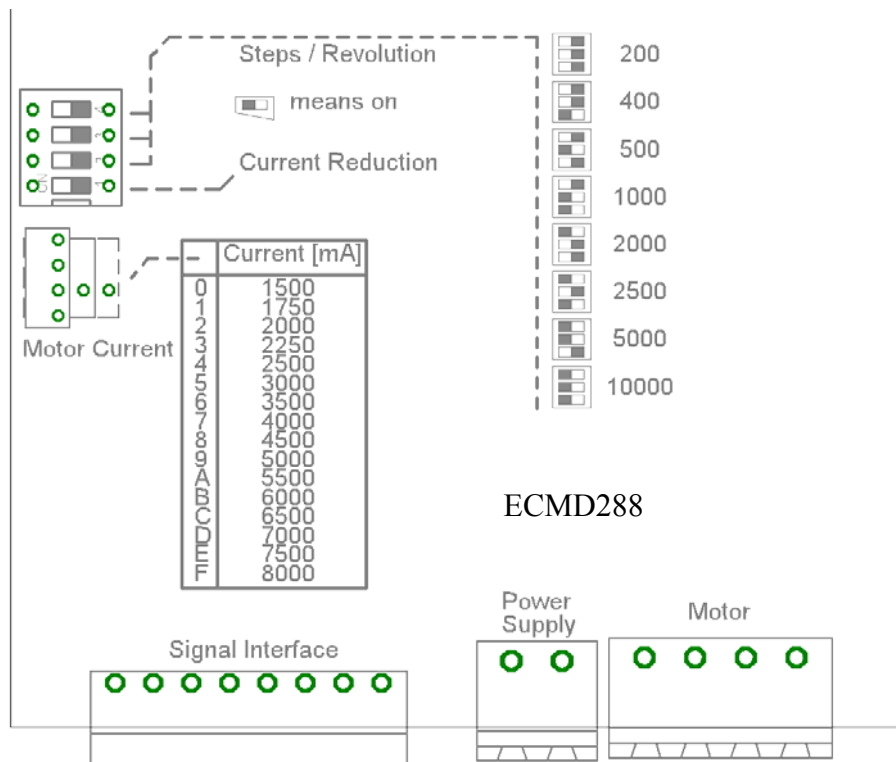

Wiring Diagram

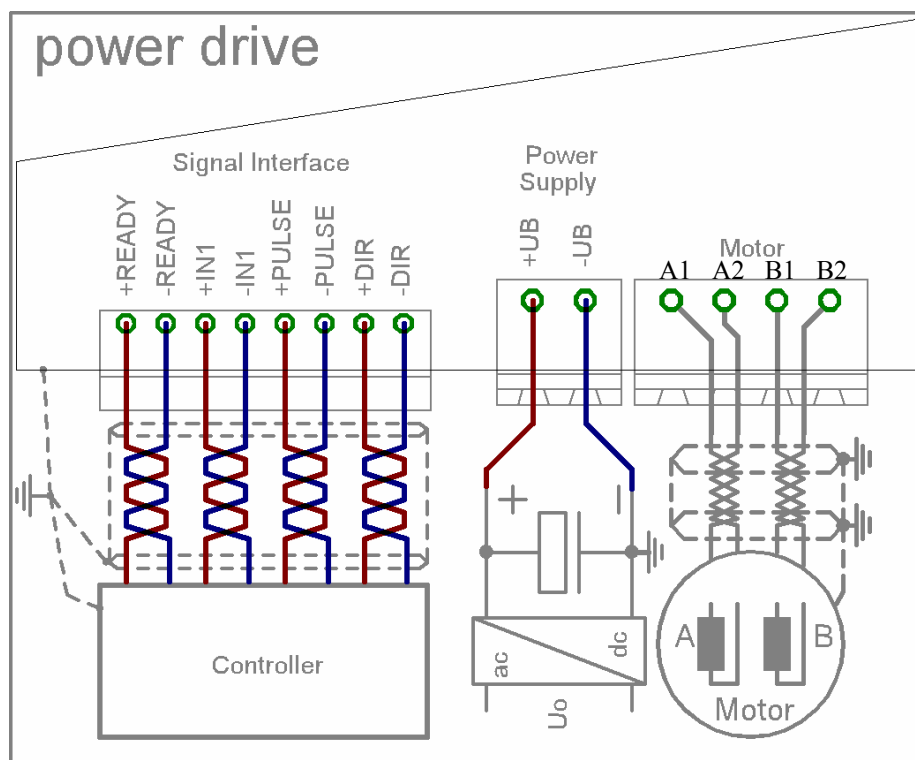

Motor connection bipolar parallel: **A1** = black and white/orange **B1** = red and white/yellow
A2 = orange and black-white **B2** = yellow and white/red

Motor connection bipolar serial: **A1** = black **A2** = orange **B1** = red **B2** = yellow

Signal Description:

Pulse, Dir and **IN1** are wide range inputs and can be operated with 3.5...24V signal voltage.

PULSE: (Pulse)

A step is executed with each positive signal edge. The power drive exclusively reacts on signal edges. In case of an active current reduction (switch „current reduction“ on) and pulse pauses greater than approx. 1s, the motor current is reduced to approx. 60% of the set value.

DIR: (Direction)

The direction signal defines the sense of motor rotation. The logic assignment can be inverted by swapping the wires of one motor phase.

IN1: (OFF standard)

Input IN1 is an auxiliary input that can be defined for different tasks. Per default the function of the input is “OFF“. The motor is switched off by activating the input “OFF“. The current chopper is switched off. This feature is occasionally used in measuring equipment to be able to measure even the smallest signal amplitudes without interference. This condition allows to move the motor manually.

READY: (READY)

This output is switched on when the drive is functional. In an error state the contact is opened, the condition is indicated with LED L.

Status display with L

Ready: L1 on

Error: L flashes (see below):
2x Low-voltage occurred
3x Over-temperature
4x Over-current detected

The fault state can be reset with input IN1.

POWER SUPPLY: (+Ub, -Ub)

The drive can be operated in the range of 24 to max. 80 Volt. It must be guaranteed that the power supply voltage at no load and +10% mains over-voltage does not exceed 80 Volt and that there is a sufficient charge capacitor of at least 6800µF.

Never connect live supply voltage wires to the terminals, because the sudden charge current of the internal electrolytic capacitors can destroy the internal fuses

! CHECK FOR CORRECT POLARITY

MOTOR CONNECTION:

By swapping a phase, e.g. phase A1 and A2 the motor sense of rotation can be inverted to the logic assignment of the direction signal „DIR“.

Under no circumstances motor wires must be disconnected during operation. Induction voltages can destroy the power drive. For this reason assure proper contact of the motor wires at the screw terminal.

Signal Interface Wiring Examples: low active, high active or RS422

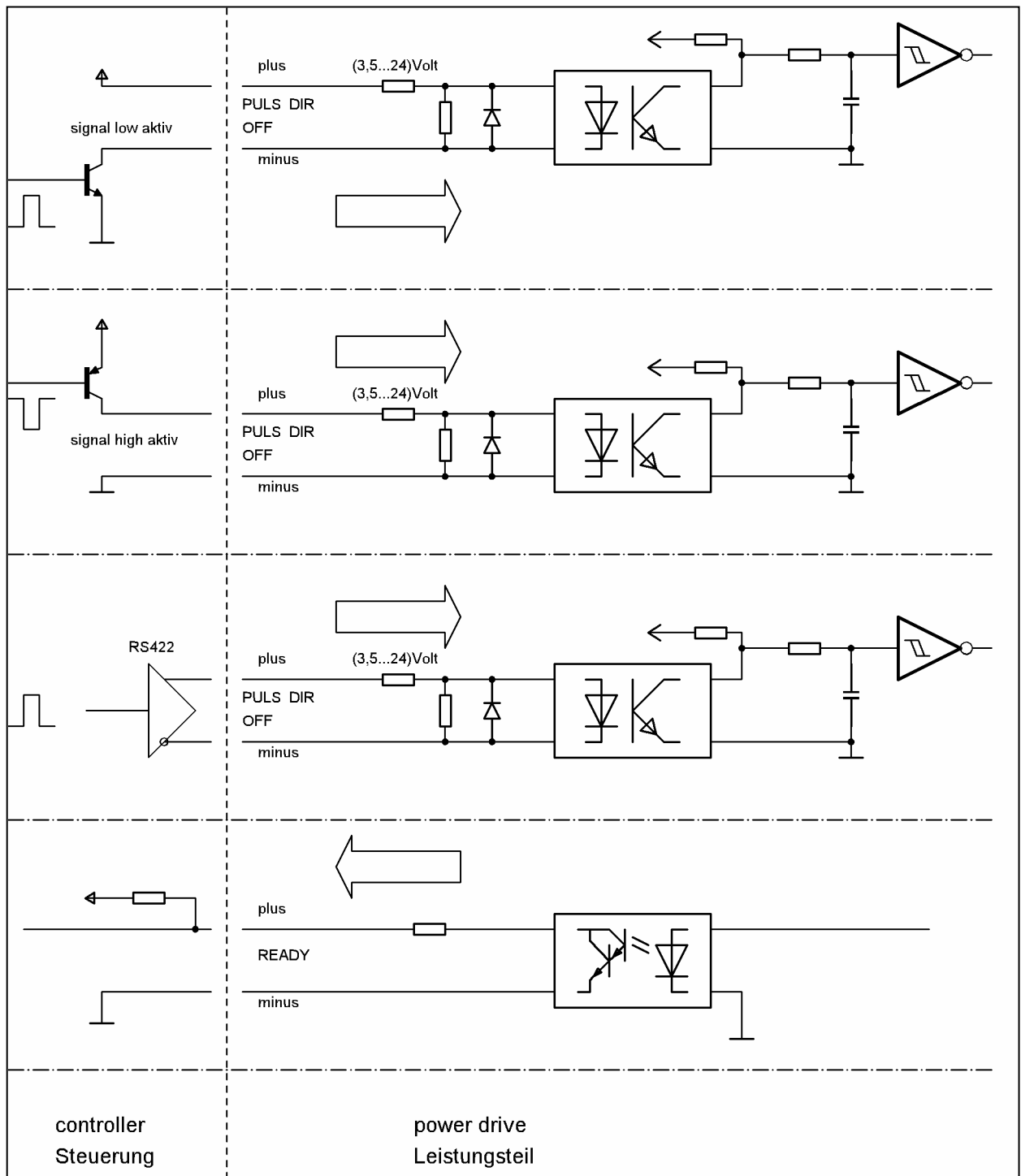

The signal interface is completely isolated by opto-isolators. To have a wide flexibility, both inputs plus and minus of the opto-isolators are available. So its easy to drive the signal interface with high-, low- or RS422 active signals

All signals have a wide range voltage input and can be operated with signal voltage levels between 3.5V to 24V .

Signal Timing

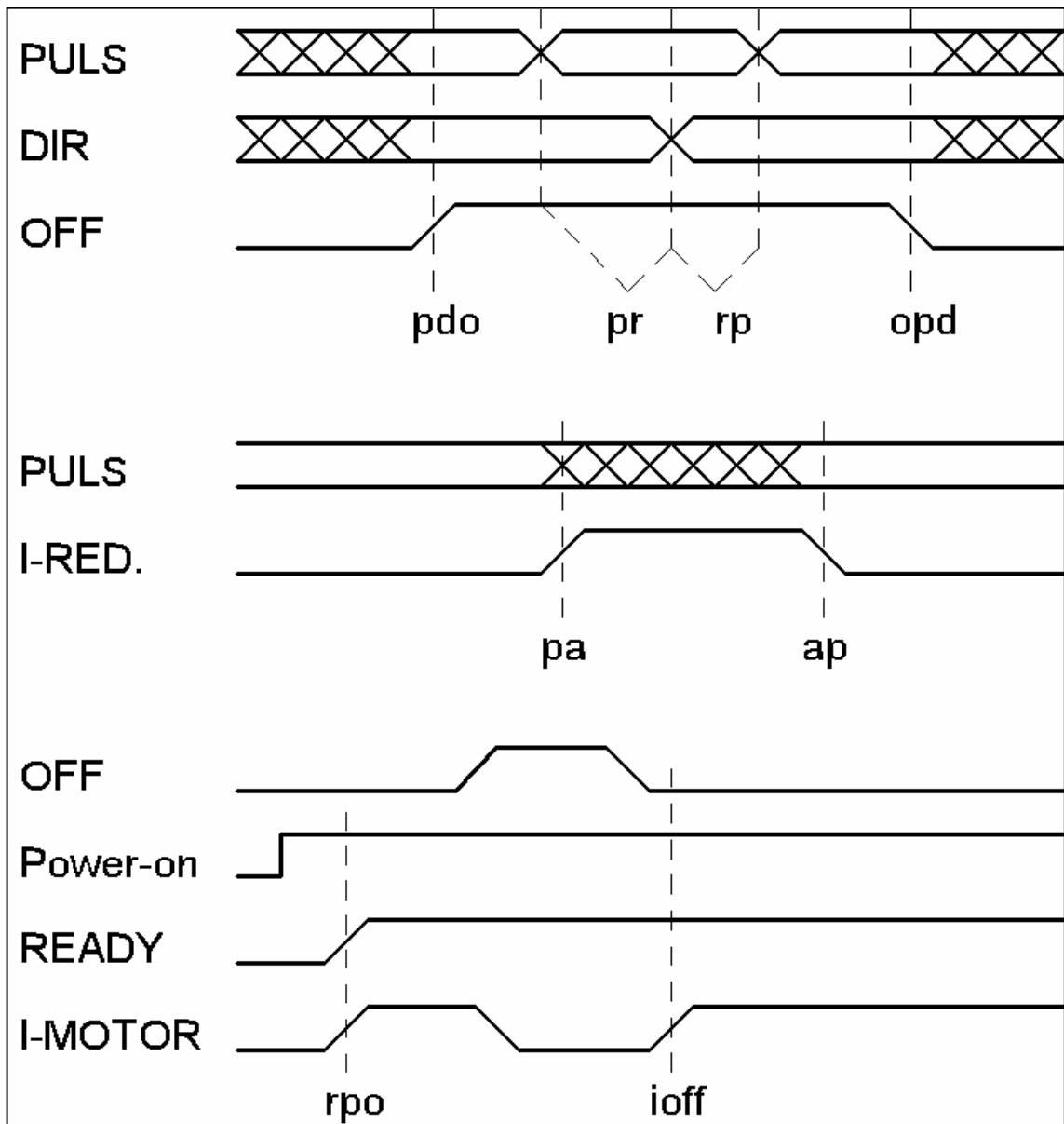

! Pulse slope: < 2 μ s
! Pulse width:> 5 μ s

pdo:	> 5 μ s	OFF active after PULSE, DIR
opd:	> 10ms	PULSE, DIR active after OFF
pr:	> 5 μ s	PULSE before DIR
rp:	> 5 μ s	PULSE after DIR
pa:	1s	Current Reduction active after PULSE
ap:	<500 μ s	Current Reduction deactivate after PULSE
rpo:	< 1s	READY after power on
ioff:	< 10ms	motor current after OFF

STEP RESOLUTION: (steps per revolution)

Select the steps/revolution with the DIP-switch.

Using a standard hybrid stepper motor with 50 magnetic

poles result in following steps/revolution:

200, 400, 500, 1000, 2000, 2500, 5000 and 10000

Running performance:

☺ less than 400 ☹ 400 ☺ more than 400

The step performance improves with higher motor current (set nominal motor current)

Behavior of resonance

The motor resonance can be reduced by increasing the steps/revolution. Following table will show the effect under the condition the resonance at full step will be 100%

steps/rev.:	behavior of resonance
200	100%
400	29%
1000	8%

MOTOR CURRENT SETTING: (motor current)

The motor current is set precisely with the HEX switch.

In general only as much current should be set as actually is required for the application. (see also "Operating Elements" on page 4).

Dimensions

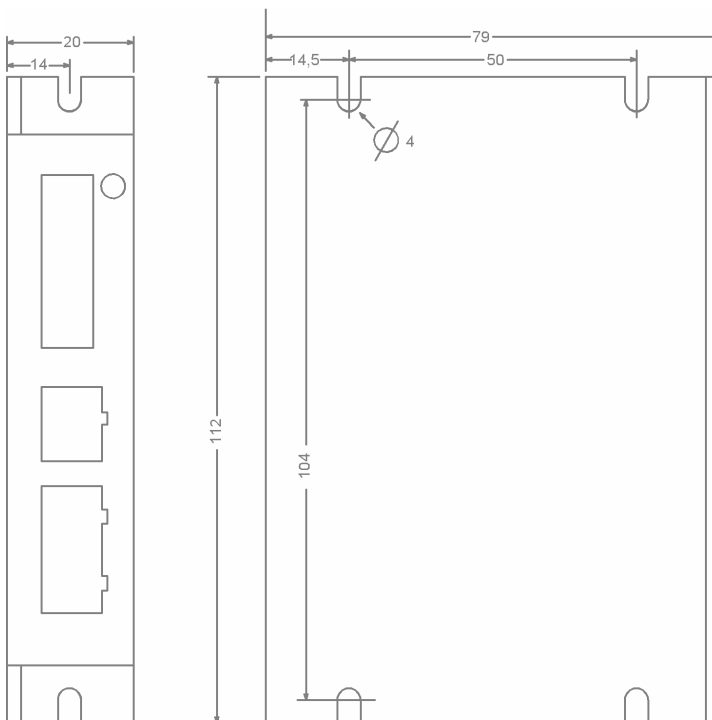

The set motor current value represents the peak current I_{PEAK} of one phase. The calculate RMS current per phase is $I_{RMS} = I_{PEAK}/\sqrt{2}$. The effective motor phase current I_m generating the motor torque results from the geometrically added phase currents I_a and I_b : $I_m = \sqrt{I_a^2 + I_b^2}$

Because of the motor inductance the set motor current value can not be reached a higher step frequency rates. Consequently the motor torque drops at higher speeds (see torque/speed characteristic diagrams of the motor manufacturer) We recommend a high current motor version with low inductance or a higher motor voltage (! don't exceed max. voltage).

Automatic current reduction is recommended.

We recommend to attach our Heat-Sink and/or suitable Colling-Fan from approx. 50% of the max. Phase-Current of the driver.

CURRENT REDUCTION: (current reduction)

"Current Reduction" activates the automatic current reduction. The motor current is reduced to approximately 60% of the set motor current. The losses in the motor as well as in the drive can therefore be significantly reduced.

! Current reduction reduces holding torque. Assure the resulting holding torque is acceptable for your application.

The current reduction is activated, if the pulse input is inactive for more than approx. 1s.

At pulse frequencies less than 1 Hz it can happen that the current reduction is briefly switched on. To avoid this effect the start/stop-frequency should be set significantly higher than 1 Hz. Immediately after detecting an active pulse input nominal current is restored.

It is recommended to generally activate the current reduction. Practical experience values show that the temperature can be reduced more than 10°C

SPECIFICATIONS:

Power drive supply:

Absolute max. voltage:	80Vmax.
Minimum voltage:	21V
Recommended voltage	24..78 V
Voltage ripple:	< 2.0V peak
Input peak current at power on:	< 2.0A peak
Fusing:	3,0 A medium
Power supply charge capacitor:	>6800µF
Power supply cable cross section:	0,75mm ²
Distance to power supply capacitor:	< 1m

Motor connection:

Cable cross section:	>0,75mm ²
Cable length:	<10m

Signal input interface: (wide range 3.5V to 24V)

Input type:	opto isolator, reverse polarity protected
Input voltage:	low: <1V
	high: >3.5V
	nominal: >4.5V
	max: <28V
Input current:	< 16 mA
Pulse width:	> 2.5µs
Pulse slope:	< 2µs

Ready:

Output type:	opto isolator
Switching voltage:	min. 3 V
	max. 30 V
Switching current:	< 50 mA
Impedance:	<20 Ohm
Load:	non-reactive

Motor current setting:

Hex-Switch, 16 steps	1.5...8A
----------------------	----------

Ambient conditions: (for $U_b < 50V$, free standing)

Temperature:	I_{Motor} 1.5A	50° max
	I_{Motor} 2.5A	45° max
	I_{Motor} 6.0A	30° max
	I_{Motor} 6...8.0A	only with heat sink

Heat-Sink: **We recommend to attach our Heat-Sink and/or suitable Cooling-Fan from approx. 50% the max. Phase-Current of driver**

UL94V-1 all components

IP20

TROUBLE SHOOTING:

Motor has no holding torque but supply voltage is connected

- The motor voltage is below the minimum value
- Signal inputs "Off" is active

Motor has holding torque, but doesn't execute steps

- The pulse signal level is too low

Sudden "crackling" noises in the motor

- Motor is operated at the minimum voltage limit
- The motor connection is bad

The motor doesn't reach the set speed but starts

- The motor voltage is too low for the required speed
- The motor current was set too low
- The acceleration ramp was set too high
- Motor wires are too long or too small cross section
- Power supply is not powerful enough

The motor "loses" steps and drifts

- The amplitudes of the control signals are too low
- Signal cable noise is too high (shielded cables?)
- The wiring concept is not optimal (all ground signals must be connected one common potential)
- The mechanical shaft coupling has play
- The motor stalls and can't follow

Motor vibrates at pulse frequency and doesn't start

- Start/Stop-frequency too high
- Motor windings are connected wrong or broken cable
- The automatic current reduction remains active (pulse duration too low at low pulse frequencies)
- The motor current is set too low

The automatic current reduction doesn't work

- The pulse input remains active after the last
- The current reduction is not enabled

The motor is hot

Up to 85 ° Celsius should be no problem

The power drive ICs are hot

Up to 85 ° Celsius should be no problem

Poor step accuracy

- Motor inductance is too high
- Motor current setting is too low

GENERAL INSTALLATION REQUIREMENTS

The device housing¹ must be grounded separately. In most cases a wing nut on the front panel or another grounding connection is available. Each component must be grounded with a separate grounding wire at a central "grounding point". This is usually the machine bed or a grounding rail inside the electrical cabinet.

Before installation and setup make sure that the required drive power is sufficient for your application and that the maximum values are not exceeded.

Mounting orientation is vertical, make sure air intake¹ and cooling slots are not blocked.

Only shielded motor cable must be installed. For identical potential between motor flange and power drive (short distance) the shield is grounded on both ends. Otherwise it is recommended to ground only the device end and that the shield on the motor end is ground connected galvanically isolated via a capacitor.

In general the ground potential difference must be in the range of only a couple mV.

For symmetrical motor cables such as with 2 phase steppers twisted pair wires are recommended per circuit.

Signal cables must also be shielded. Twisted pair wires are recommended per circuit.

The ground potential common point should be located directly at the housing or the mounting point of the power drive.

Signal cable and motor cable must be separated. Long parallel cable installation must be avoided. Cable crossings (if necessary) should be installed vertically.

Check all device settings for validity.



EC MOTION GMBH
Auf den Steinen 20
41812 Erkelenz
Germany

SAFETY AND PROTECTION REQUIREMENTS

The installation of the device must only be conducted by an educated, trained and experienced expert (electro). The local guidelines for safety, installation of electrical and mechanical systems and EMI must be observed.

Unintended operation and faulty installation of the device can lead to personal injury (incl. the possibility of death) and the device as well as other external components can be damaged or an excessive pollution of the environment can occur.

Operation is only permitted with the mounted housing². Because of eventually present high voltage the device must not be opened (also not after a long period of idle time). Make sure children have no direct access to the device.

No technical modifications of the device are permitted.

The device housing³ must be grounded separately. In most cases a wing nut on the front panel or another grounding connection is available. The device must be grounded prior to the installation.

Under no circumstances live or functional connectors must be removed or connected. All installations must be conducted in the powerless de-energized state.

Device operation in damp, humid environment or with present spray water is not permitted.

¹ if available

² not with open frame (only PCBs)

³ if available