



Operator Manual

2-Phase Stepping Motor Power Drive

ECMD241

Motor-Current from 0,5 up to 1,25 A / Phase

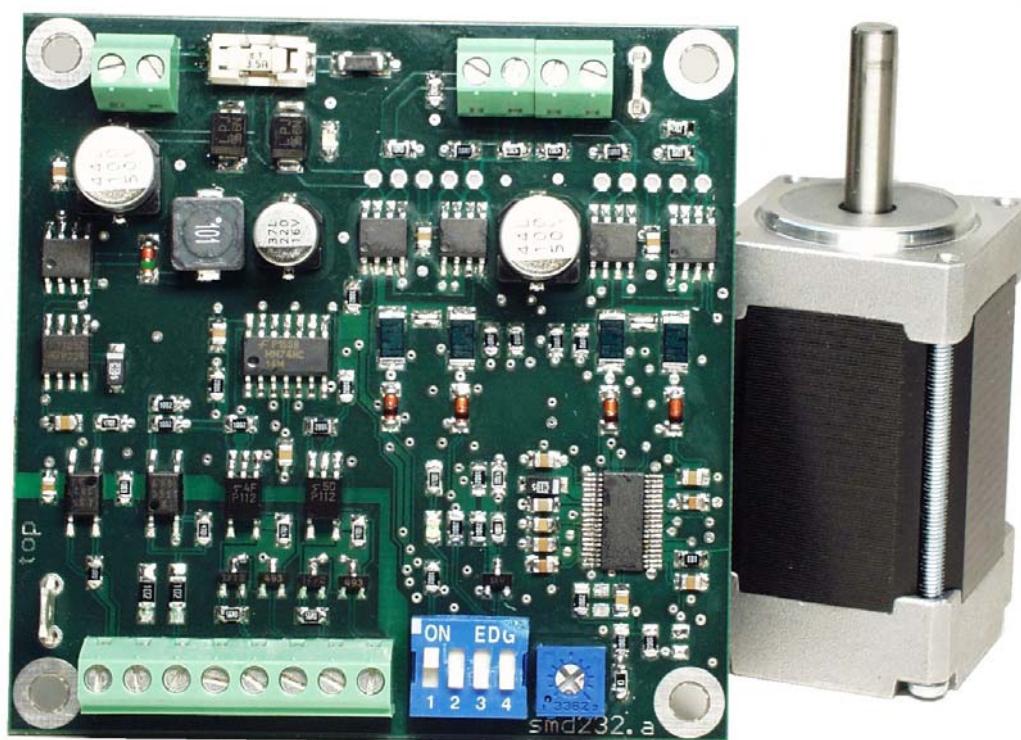

Product Features

- For all common 2-phase stepping motors
- Preferably up to motor flange sizes 42 (NEMA17), sizes 56 (NEMA23) and size 60 mm
- Bipolar drive: chopped, reduced noise and losses
- Only one power supply necessary: 24...40 Volt
- Simple motor current adjustment with potentiometer (0,5...1,25)A
- Step rates: full, half, quarter and sixteenth respectively 200, 400, 800 and 3200 steps/rev
- automatic current reduction (switchable)
- robust screw terminal for all connections
- Compact size L:W:H (72:72:12) mm
- Inputs: PULSE, DIRECTION, OFF (opto coupler)
- Outputs: READY (opto coupler)
- Step frequency up to 80 kHz
- LED indicators for supply voltage and current reduction

Options:

- DIN rail housing module HSM.02
- High-Current-Version ECMD242 (1,0 - 2,5 A / Phase)

Ordering Number Key

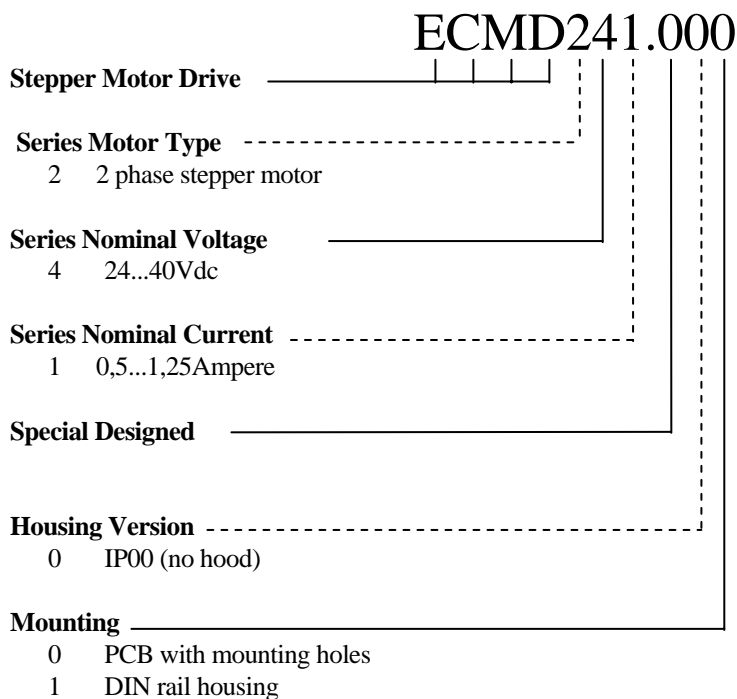

Leadwire Connection

for Step Motor HECM24... Series:

- A1 = black
- A2 = green
- B1 = red
- B2 = blue

for Step Motor SECM24... Series

- A1 = black
- A2 = green
- B1 = red
- B2 = blue
- not connected = yellow and white

for Step Motor SECM243-F1.3(A/B) and for Step Motor SECM244-F1.1(A/B)

- A1 = blue
- A2 = red
- B1 = yellow
- B2 = white

for Step Motor HECM26... Series and for Step Motor SECM26... Series

- A1 = black and white/orange
- A2 = white/black and orange
- B1 = red and white/yellow
- B2 = white/red and yellow

Accessories (separate order items)

HUT241/242 DIN rail housing option

Placement of the operating elements

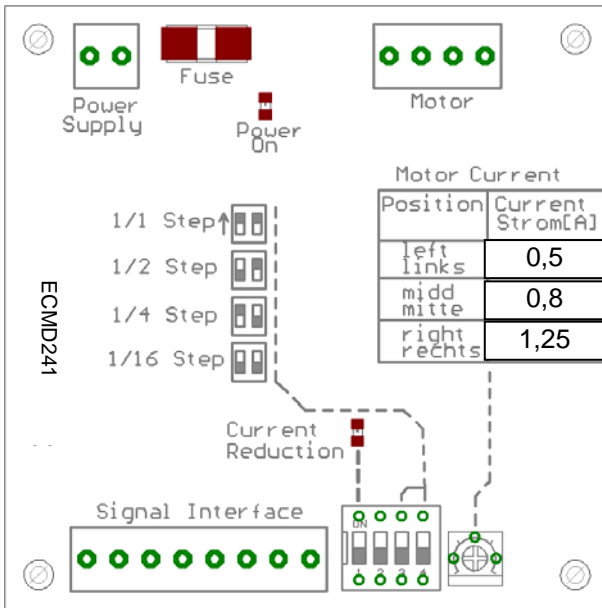

PULSE: (Pulse)

A step is executed with each positive signal edge. The power drive exclusively reacts on signal edges. In case of an active current reduction (switch "current reduction" on) and pulse pauses greater than approx. 100ms, the motor current is reduced to approx. 75% of the set value.

The current reduction is not active if the pulse signal stays on active

DIRECTION: (Dir)

The direction signal defines the sense of motor rotation. The logic assignment can be inverted by swapping the wires of one motor phase.

OFF: (Off)

When active, the motor current is switched to zero. The current chopper is switched off entirely. This feature is sometimes used in measuring equipment to measure small signal levels without interference by the stepping motor. The motor shaft can now easily be rotated manually.

READY: (Ready)

This output is switched on (low impedance) when the drive is functional. Low supply input voltage switches the output off (high impedance).

POWER SUPPLY: (+Ub, -Ub)

The power drive can be within the range of 21..40Vdc. It must be guaranteed that the power supply does not exceed 40V at no load condition and with 10% line over voltage. The power supply must also have an output capacitor of at least 6800µF.

Never connect live supply voltage wires to the terminals, because the sudden charge current of the internal electrolytic capacitors can destroy the internal fuses

! Check for correct polarity

MOTOR CONNECTION: (A1,A2,B1,B2)

By swapping the wiring connection of one motor phase, e.g. phase A, the motor sense of rotation can be inverted to the logic assignment of the direction signal DIR.

Under no circumstances motor wires must be disconnected during operation. Induction voltages can destroy the power drive. For this reason assure proper contact of the motor wires at the screw terminal.

Wiring diagram

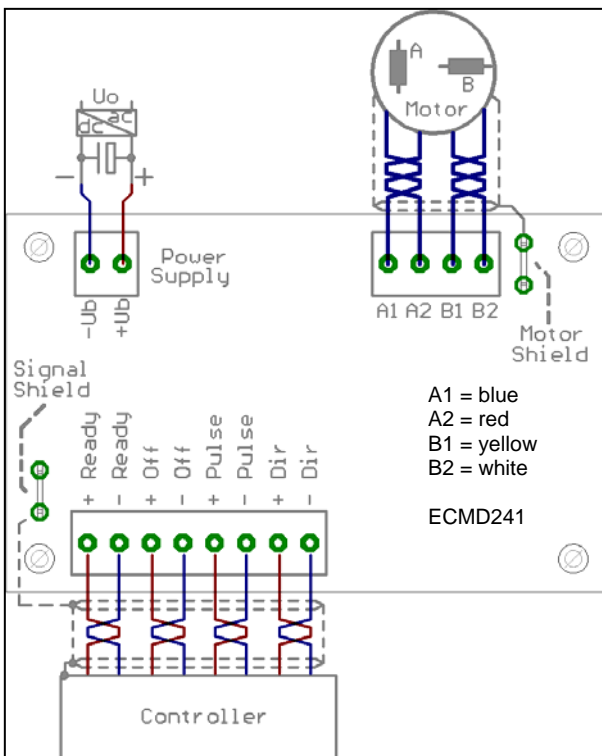

Signal description

The inputs **Off**, **Pulse** and **Dir** are wide range inputs and can be operated with 3,5...24V signal voltage.

Signal Interface

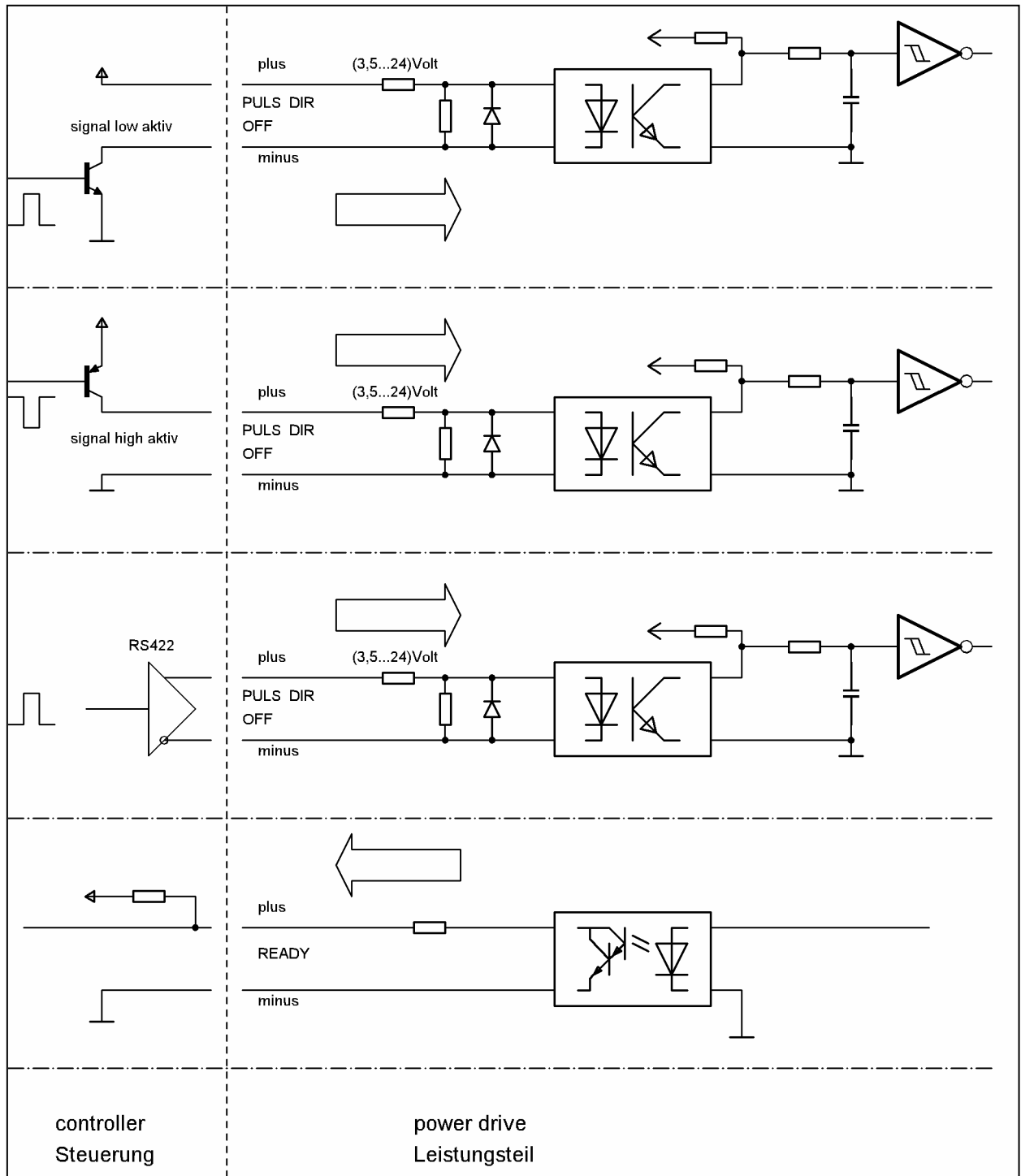

The signal interface is completely isolated by opto couplers. To have a wide flexibility, both inputs plus and minus of the opto couplers are available. So its easy to drive the signal interface with high-, low- or RS422 active signals.

All signals have a wide voltage range from 3.5V...24V.

Signal Timing

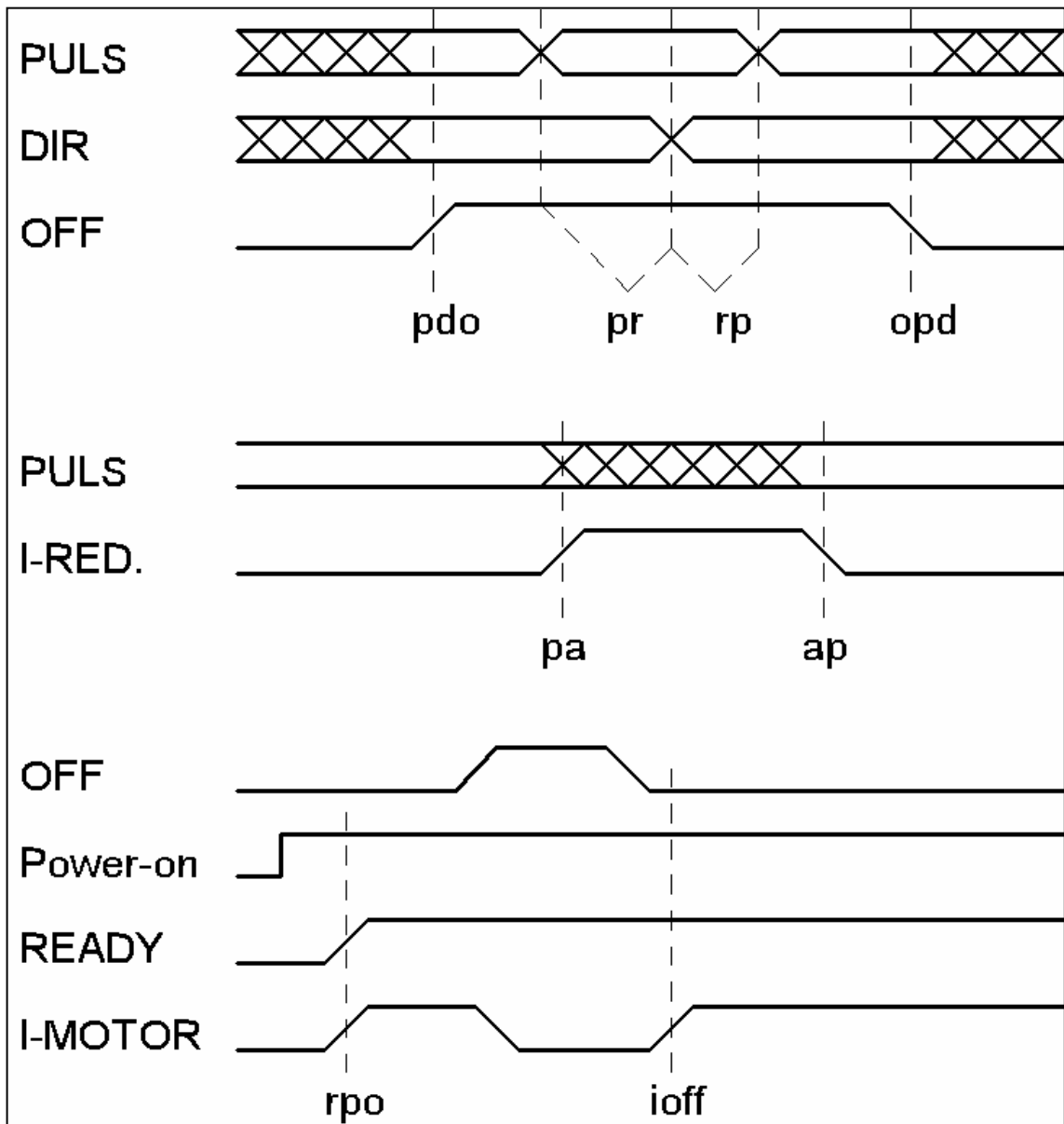

! Pulse slope: < 2 μ s
! Pulse width:> 5 μ s

pdo:	> 5 μ s	OFF active after pulse, direction
opd:	> 10ms	pulse, direction active after OFF
pr:	> 5 μ s	pulse before direction
rp:	> 5 μ s	pulse after direction
pa:	<150ms	current reduction active after pulse
ap:	<500 μ s	current reduction deactivate after pulse
rpo:	< 1s	ready after power on
ioff:	< 10ms	motor current after OFF

STEP RATE:

Fullstep, halfstep, quarter-step and sixteenth-step can be set. Using a standard hybrid stepper motor with 50 magnetic poles result in following steps/revolution: 200, 400, 800 and 3200.

Running performance:

☹ less than 400 ☹ 400 ☺ more than 400

The step performance increases with lower motor voltage and higher motor current (set nominal motor current).

Behavior of resonance

The motor resonance can be reduced by increasing the steps/revolution. Following table will show the effect under the condition the resonance at full step will be 100%

Steps/rev.:	Behavior of resonance:
200	100%
400	29%
800	8%

MOTOR CURRENT SETTING:

In general only as much current should be set as actually is required for the application. Too high motor currents results in unnecessary losses in motor and drive.

At higher pulse rates the motor current reduces because of the motor inductance. (see diagrams from manufactures)
In this case a low inductance motor is recommended.

Above 1.5 Amp continuous motor phase current, the drive must be cooled by forced air flow. Automatic current reduction is recommended.

CURRENT REDUCTION:

“Current Reduction“ activated the automatic current reduction. The motor current is reduced to approx. 75% of the set motor current. The losses in motor and drive are reduced significantly. The current reduction is activated, if the pulse input is inactive for more then approx. 100ms. This condition is then indicated with a yellow LED. With pulse frequencies less than 10Hz it can happen that the current reduction becomes active for a short period of time. To avoid this behavior the Start/Stop-frequency should be significantly higher than 10Hz. With the next pulse, the current reduction is disabled immediately and the nominal current is set again.

The current reduction can be blocked if the pulse input remains in a static active level.

It is recommended to generally activate the current reduction. Practical experience values show that the temperature can be reduced more than 10°C.

! Current reduction reduces holding torque. Assure the resulting holding torque is acceptable for your application.

PCB DIMENSIONS (in mm):

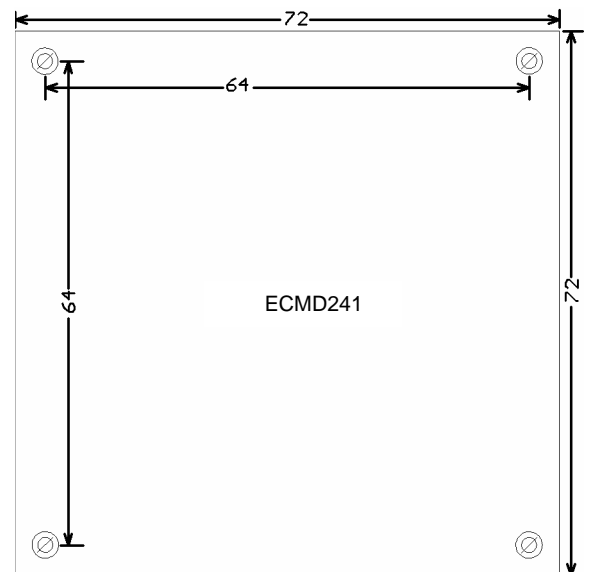

Overall height of the power drive including the PCB: 12mm

TECHNICAL SPECIFICATIONS:

Power drive supply:

Absolute max. voltage:	42V
Minimum voltage:	21V
Recommended voltage	24...38V
Voltage ripple:	< 2.0V peak
Input peak current at power on:	< 2.0A peak
Fusing:	3.5A medium
Power supply charge capacitor:	>6800 μ F
Power supply cable cross section:	0,75mm ²
Distance to power supply capacitor:	< 1m

Motor connection:

Cable cross section:	>0,5mm ²
Cable length:	<10m

Signal input interface: (wide range 3.5V to 24V)

Input type:	opto coupler, reverse polarity protected		
Input voltage:	low:	<1V	
	high:	>3.5V	
	nominal:	>4.5V	
	max:	<28V	
Input current:	< 16 mA		
Pulse width:	> 5 μ s		
Pulse slope:	< 2 μ s		

Ready:

Output type:	opto coupler		
Switching voltage:	min.	3 V	
	max.	30 V	
Switching current:	< 50 mA		
Impeadance:	<20 Ohm		
Load:	only ohmic		

Motor current setting:

Potentiometer	0.5...1.25A
---------------	-------------

Current reduction, active at frequencies lower than

Pulse width:	5 μ s	10 μ s	50 μ s	100 μ s
Current red.:	50Hz	30Hz	20Hz	15Hz

Ambient conditions:

Temperature:	I _{Motor} 1.0A	45° max
	I _{Motor} 1.5A	37° max

UL94V-1 all components IP00

HELP WITH PROBLEMS:

Motor has no holding torque but supply voltage is connected

- The motor voltage is below the minimum value
- Signal inputs "Off" is active

Motor has holding torque, but doesn't execute steps

- The pulse signal level is too low

Sudden "crackling" noises in the motor

- Motor is operated at the minimum voltage limit
- The motor connection is bad

The motor doesn't reach the set speed but starts

- The motor voltage is too low for the required speed
- The motor current was set too low
- The acceleration ramp was set too high
- Motor wires are too long or too small cross section
- Power supply is not powerful enough

The motor "loses" steps and drifts

- The amplitudes of the control signals are too low
- Signal cable noise is too high (shielded cables?)
- The wiring concept is not optimal (all ground signals must be connected one common potential)
- The mechanical shaft coupling has play
- The motor stalls and can't follow

Motor vibrates at pulse frequency and doesn't start

- Start/Stop-frequency too high
- Motor windings are connected wrong or broken cable
- The automatic current reduction remains active (pulse duration too low at low pulse frequencies)
- The motor current is set too low

The automatic current reduction doesn't work

- The pulse input remains active after the last
- The current reduction is not enabled

The motor is hot

Up to 85 ° Celsius should be no problem

Tie power drive ICs are hot

Up to 85 ° Celsius should be no problem

Poor step accuracy

- Motor inductance is too high
- Motor current setting is too low

GENERAL INSTALLATION REQUIREMENTS

The device housing¹ must be grounded separately. In most cases a wing nut on the front panel or another grounding connection is available. Each component must be grounded with a separate grounding wire at a central "grounding point". This is usually the machine bed or a grounding rail inside the electrical cabinet.

Before installation and setup make sure that the required drive power is sufficient for your application and that the maximum values are not exceeded.

Mounting orientation is vertical, make sure air intake¹ and cooling slots are not blocked.

Only shielded motor cable must be installed. For identical potential between motor flange and power drive (short distance) the shield is grounded on both ends. Otherwise it is recommended to ground only the device end and that the shield on the motor end is ground connected galvanically isolated via a capacitor.

In general the ground potential difference must be in the range of only a couple mV.

For symmetrical motor cables such as with 2 phase steppers twisted pair wires are recommended per circuit.

Signal cables must also be shielded. Twisted pair wires are recommended per circuit.

The ground potential common point should be located directly at the housing or the mounting point of the power drive.

Signal cable and motor cable must be separated. Long parallel cable installation must be avoided. Cable crossings (if necessary) should be installed vertically.

Check all device settings for validity.

EC Motion GmbH
41812 Erkelenz - Auf den Steinen 20
Internet: www.ec.-motion.de

SAFETY AND PROTECTION REQUIREMENTS

The installation of the device must only be conducted by an educated, trained and experienced expert (electro). The local guidelines for safety, installation of electrical and mechanical systems and EMI must be observed.

Unintended operation and faulty installation of the device can lead to personal injury (incl. the possibility of death) and the device as well as other external components can be damaged or an excessive pollution of the environment can occur.

Operation is only permitted with the mounted housing². Because of eventually present high voltage the device must not be opened (also not after a long period of idle time). Make sure children have no direct access to the device.

No technical modifications of the device are permitted.

The device housing³ must be grounded separately. In most cases a wing nut on the front panel or another grounding connection is available. The device must be grounded prior to the installation.

Under no circumstances live or functional connectors must be removed or connected. All installations must be conducted in the powerless de-energized state.

Device operation in damp, humid environment or with present spray water is not permitted.

Tel.: +49 – 2164 - 7014-0
Fax: +49 – 2164 - 701419
Email: info@ec-motion.de

¹ if available

² not with open frame (only PCBs)

³ if available